

# LJA Series Safety Limit Switches

## FEATURES

Snap Action Mechanism Built-in Safety Limit Switches with Contact Forced Open Mechanism Absolutely Required to Make General Industrial Machines Applicable to EC Directives and to Acquire the CE Marking.

- $\text{\textcircled{E}}$  mark (symbol mark for control switch with positive open circuit operation) is provided to ensure acquisition of the EN standard approval.
- Safety limit switch conforming to the EN 50041 standard.
- UL/CSA/CE markings are provided, suitable for machines to be exported to North America and Europe.
- N.C./N.O. electrically independent contact (Zb) is achieved with the snap action mechanism.
- Use of twin-contact structure improves the contact reliability.
- Mounting pitch compatible with that of LS general purpose limit switch having abundant excellent operation results.
- A wide variety of actuators provided.
- High sealing ability applicable to immersion proof type (JIS) and IP67 (IEC 60529).

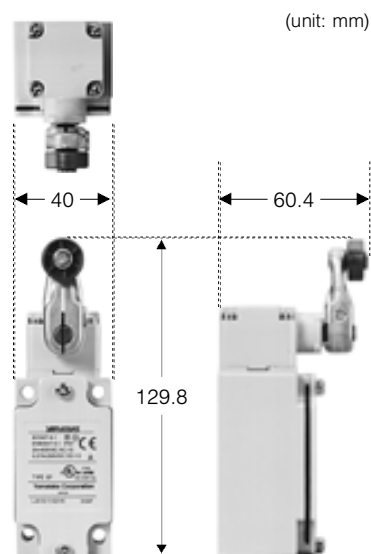

The above photo shows the roller lever type switch.  
For details about dimensions, see relevant drawings.

## ORDER GUIDE

Actuator type	Catalog listing	Operating characteristics		
		O.F. (Max.) Operating force	P.T. (Max.) Pretravel	M.D. (Max.) Movement differential
Standard roller lever (Lever length: 30mm)	<b>LJA10-11A21N</b>	11.8N	25°	13°
Adjustable roller lever	<b>LJA10-13A21N</b>	11.8N	25°	13°
Boot seal roller plunger	<b>LJA10-57A21N</b>	18.6N	3mm	1.3mm

## INTERNAL SWITCH: N.C./N.O. electrically independent contact (Zb)

The internal switch of the **LJA** Series has the N.C./N.O. electrically independent contact (Zb) and twin-contact structure.

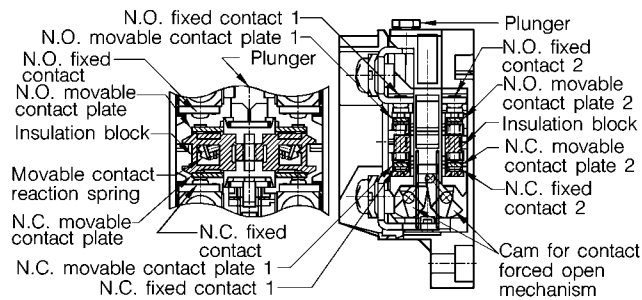

The movable contact plates for the N.C. and N.O. contacts are independent from each other and insulated mutually. Additionally, this switch is a type of two-circuit and double-breaking switch using twin contacts.

## OPERATIONAL DESCRIPTION OF LJA INTERNAL SWITCH

• Conventional LS general purpose limit switch

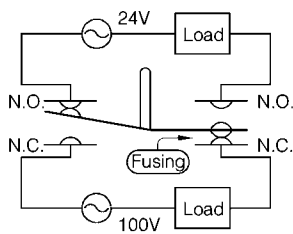

In the conventional two-circuit and double-breaking switch, if fusing occurs at the N.C. contact and the switch is activated, the line between N.C. and N.O. may enter the electrical continuity state. If this occurs, the power supply circuit may be short-circuited or the load may be burnt depending on the circuit configuration.

• LJA switch

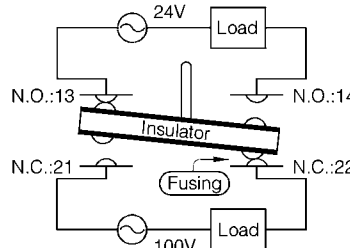

In the **LJA** Series switch, even if fusing occurs and the switch is activated, the line between N.C. and N.O. does not enter the electrical continuity state. Therefore, even though a separate power supply is put on the N.C. and N.O. sides as shown in the above Fig., the short-circuited power supply and burnt load can be avoided.

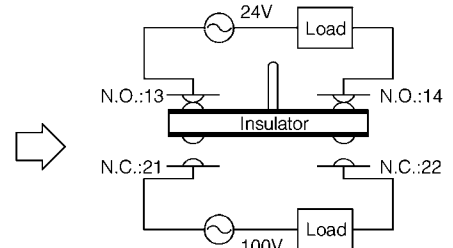

Additionally, as the switch is pushed in, the cam is rotated to push up the N.C. contact plate and to forcibly release the fused contact.

## FORCED OPEN MECHANISM BY CAM (N.C. contact only)

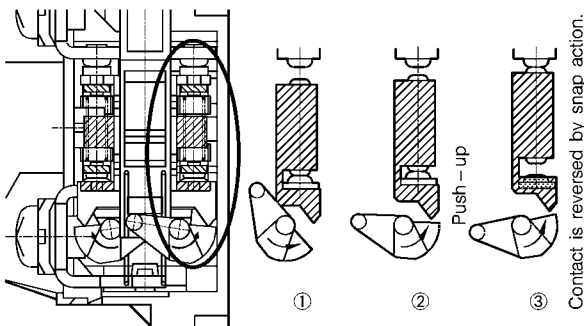

As shown in the above Fig., the cam forcibly pushes up the N.C. contact from the bottom. With this mechanism, the contact is forcibly opened even though the contact is fused.

## PERFORMANCE

Standards	Normative standards	JIS C 4508/JIS C 8201-5-1, IEC 60947-5-1, EN 50041 (mounting hole dimension only)
	Approved standards	EN 60947-5-1 (TÜV)/UL (E 96090)/CSA
Structure	Contact type	Zb (EN 60947-5-1) 
	Contact shape	Rivet
	Terminal shape	Screw (M3 round head screw with square washer)
	Protective structure	Immersion proof type (JIS), IP67 (IEC 529)
	Contamination degree of operating environment	Contamination degree 3 (EN 60947-5-1)
Electrical performance (1) General characteristics	Electrical rating	See separate Table 1.
	Dielectric strength	Between non-continuous terminals: 2,100Vac, 50/60Hz for 1min. Between each terminal and non-conducting metal part: 5,300Vac, 50/60Hz for 1min. Between each terminal and ground: 5,300Vac, 50/60Hz for 1min. Between different terminals: 5,300Vac, 50/60Hz for 1min.
	Insulation resistance	100MΩ or more (by 500Vdc Megger)
	Initial contact resistance	25mΩ or less (6 to 8Vdc, energizing current 1A, measured by voltage drop method)
	Recommended min. operating voltage/current	24V-10mA, 12V-20mA
Electrical performance (2) EN 60947-5-1 related characteristics	Rated operating voltage	400Vac, 250Vdc
	Rated energizing current (Ith)	10A
	Rated frequency	AC voltage, 45 to 65Hz, and DC voltage
	Short-circuit protective device	BUSSMAN fast acting fuse KTK-10 (10A) or equivalent
	Rated insulation voltage (Ui)	500Vac or 275Vdc
	Conditional rated short-circuit current	1,000A (with coil load)
	Switching over-voltage	Category 3 (IEC 204-1)
	Rated impulse withstanding voltage (Uimp)	6,000V
	Electrical protection	Class I and Class II (without use of grounding terminal) (IEC 536)
Mechanical performance	Actuator strength	Roller lever type: 49N in operating direction for 1min. or more Plunger type: 93N in operating direction for 1min. or more Rod lever type: 12N in operating direction for 1min. or more
	Terminal strength	Withstand tightening torque strength of 1.0 N-m for 1min.
	Impact resistance	300m/s <sup>2</sup> , contact open is 1ms. or less at free position and operation limit position.
	Vibration resistance	Frequency: 10 to 55Hz, Peak-to-peak amplitude: 1.5mm, Continuous 2hrs. Contact open is 1ms. or less at free position and operation limit position.
	Allowable operating speed	1mm/s to 0.5mm/s, Min. speed: 0.1s or less in the unstable contact status. Max. speed: Actuator should not be broken.
	Mechanical operating frequency	120 operations/min. or less
Life	Mechanical life	Lever type: 15million operations or more, Plunger type: 5million operations or more
	Electrical life	100,000 operations or more (rated load, open/close frequency: 20operations/min. or less)
Environmental conditions	Operating temperature range	-25 to +70°C (No freezing allowed.)
	Operating humidity range	98%RH or less
Recommended tightening torque	Body	5 to 6N-m (M5 screw)
	Terminal	0.6 to 1.0N-m (M3 round head screw with square washer)
	Cover	1.3 to 1.7N-m (M4 screw)
	Head	0.8 to 1.2N-m (M3.5 screw)
	Roller lever	4 to 5.2N-m (M5 screw)

• Installation Instructions No.: CP-SP-1104E

**Note 1.** The values stated in the above Table are common to all **LJA10** Series models.

**Note 2.** The values for the roller lever type are those obtained when the lever length is 30mm.

### • Table 1. Electrical rating

EN 60947-5-1	UL 508
AC-15: Ue=AC 400V, Ie=2A Ue=AC 240V, Ie=3A DC-13: Ue=DC 250V, Ie=0.27A	2A/400Vac General Use Load 3A/240Vac General Use Load 0.27A/240Vdc 0.55A/120Vdc

Category used AC-15: Solenoid load  
DC-13: Solenoid load

Ue: Rated operating voltage  
Ie: Rated operating current

### CONTACT SHAPE

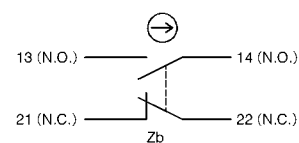

Zb :Mutually insulated twin-contact type double gap contact element with 4 terminals (EN 60947-5-1)

 :Symbol mark for control switch with positive open circuit operation (EN 60947-5-1)

## APPEARANCE, OPERATING CHARACTERISTICS, AND EXTERNAL DIMENSIONS

### ● Roller lever type

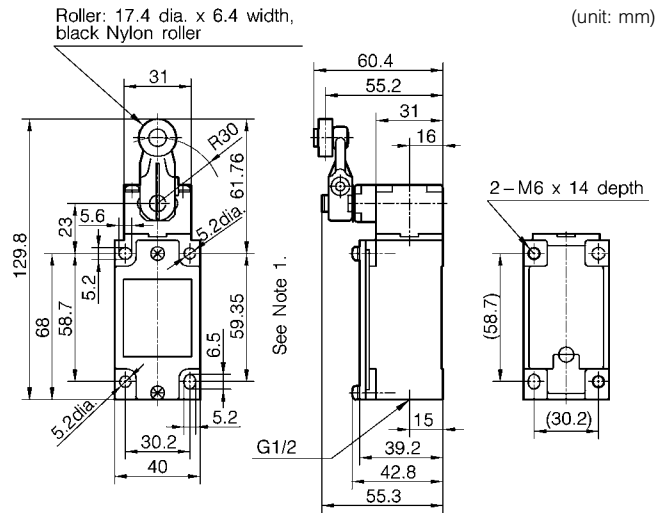

Catalog listing		LJA10-11A21N
O.F. (Operating force)	(N max.)	11.8
R.F. (Release force)	(N min.)	0.5
P.T. (Pretravel)	(° max.)	25
O.T. (Overtravel)	(° min.)	45
M.D. (Movement differential)	(° max.)	13
T.T. (Total travel)	(° min.)	70
P.O. (Travel to positive opening position)	(° max.)	55
P.O.F. (Positive opening force)	(N max.)	12.7

Note 1. A mounting pitch of 58.7 to 60 is possible.

Note 2. When using N.C. for safety, a push-in amount exceeding the P.O. point shown on the left should be kept.

### ● Adjustable roller lever

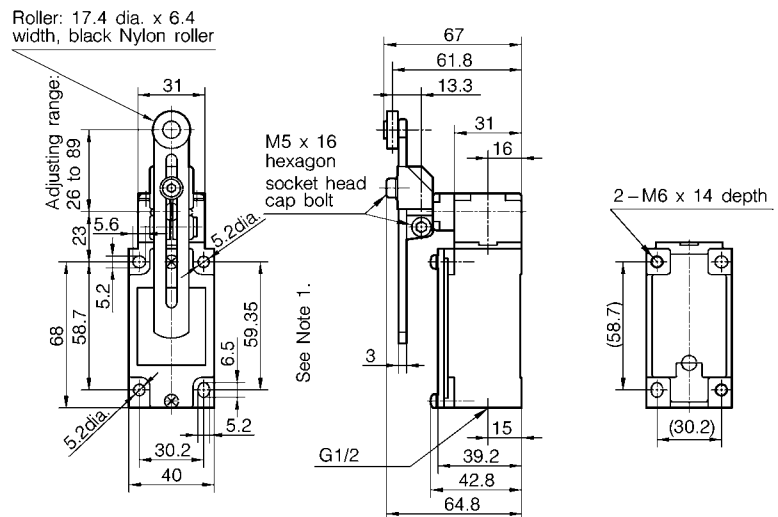

Catalog listing		LJA10-13A21N
O.F. (Operating force)	(N max.)	11.8
R.F. (Release force)	(N min.)	0.5
P.T. (Pretravel)	(° max.)	25
O.T. (Overtravel)	(° min.)	45
M.D. (Movement differential)	(° max.)	13
T.T. (Total travel)	(° min.)	70
P.O. (Travel to positive opening position)	(° max.)	55
P.O.F. (Positive opening force)	(N max.)	12.7

Note 1. A mounting pitch of 58.7 to 60 is possible.

Note 2. When using N.C. for safety, a push-in amount exceeding the P.O. point shown on the left should be kept.

● Boot seal roller plunger type

(unit: mm)

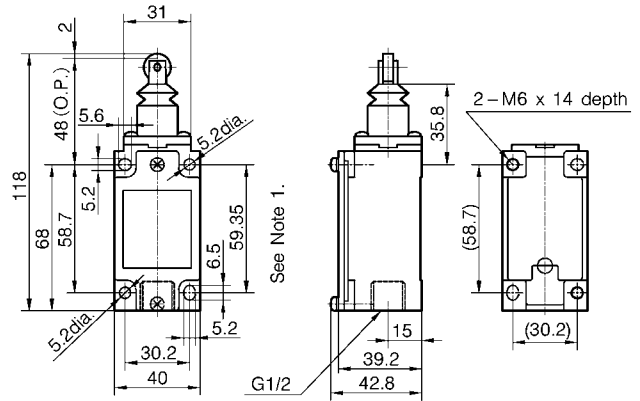

Catalog listing		LJA10-57A21N
O.F. (Operating force)	(N max.)	18.6
R.F. (Release force)	(N min.)	2.0
F.P. (Free position)	(mm max.)	51
O.P. (Operating position)	(mm)	48 ± 1
P.T. (Pretravel)	(° max.)	3
O.T. (Overtravel)	(° min.)	4.5
M.D. (Movement differential)	(° max.)	1.3
T.T. (Total travel)	(° min.)	6.5
P.O. (Travel to positive opening position)	(° max.)	5.5
P.O.F. (Positive opening force)	(N max.)	27

Note 1. A mounting pitch of 58.7 to 60 is possible.

Note 2. When using N.C. for safety, a push-in amount exceeding the P.O. point shown on the left should be kept.

**HANDLING PRECAUTIONS**

To properly and safely operate the switch, see also the separate User's Manual, "Safety Limit Switch LJA10 Series" (Installation Instructions No.: CP-SP-1104E).

● Changing the operating direction of the roller lever type switch

The roller lever type switch has been assembled at shipment so that it is operated in both directions.

It is possible to change to one operating direction (clockwise or counterclockwise operation) corresponding to the customer's operation method. To change the operating direction, follow the steps below.

**Step 1.** Loosen four screws on the operation head part to remove the operation head.

**Step 2.** Turn over the operation head, push the internal plunger guide (black cylindrical part), and then turn it to set a desired operating direction.

Make the ▲ mark on the internal plunger guide matched with the RL, R, or L character on the head to set desired operation.

RL: Operation in both directions

R: Operation in clockwise direction (CW)

L: Operation in counterclockwise direction (CCW)

**Step 3.** Reassemble the operation head to the switch body.

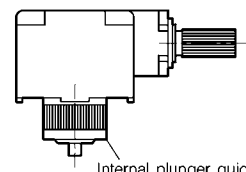
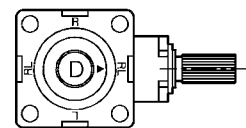

Internal plunger guide  
Step 1. Push-in the internal plunger guide.

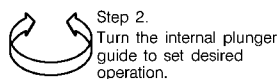

Step 2. Turn the internal plunger guide to set desired operation.

● **Mounting the switch**

The mounting of the safety limit switch **LJA** Series is compatible with that of the general purpose compact type switch **LS-J** Series. Mount the switch as shown in the following Figs:

(unit: mm)

**Mounting the LJA Series switch** (Mounting in conformity with EN 50041):

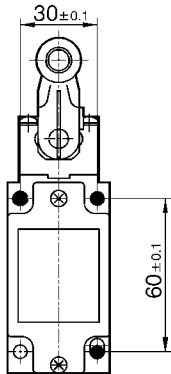

Three mounting holes indicated by “●” shown in the Fig. on the left, that is, 5.2dia. hole, oval hole 5.2×5.6, and oval hole 5.2×6.5, can be secured.

**Note.** The back mounting cannot be performed using the mounting hole having a mounting pitch of 30×60.

If the mounting compatibility with general purpose compact type switch **LS-J** Series is required:

Mounting the **LS-J** Series switch

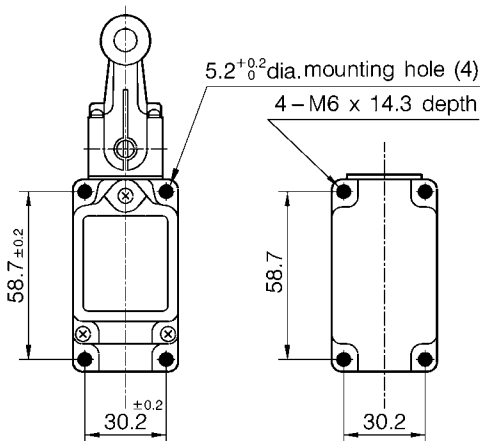

Four 5.2dia. mounting holes indicated by “●” shown in the Fig. on the left can be secured or four M6 screws on the back can be secured.

Mounting the **LJA** Series switch

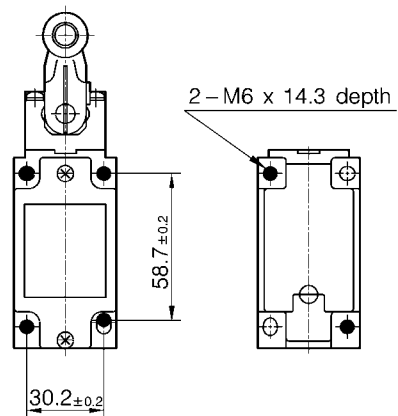

Two M6 screws diagonally opposite to each other on the back of the switch indicated by “●” shown in the Fig. can be secured, or two 5.2dia. mounting holes diagonally opposite to each other or four 5.2dia. mounting holes can be secured.

# LJM Series

## Compact Die-cast Safety Limit Switches

### FEATURES

Compact Safety Limit Switches Made of Die-cast.

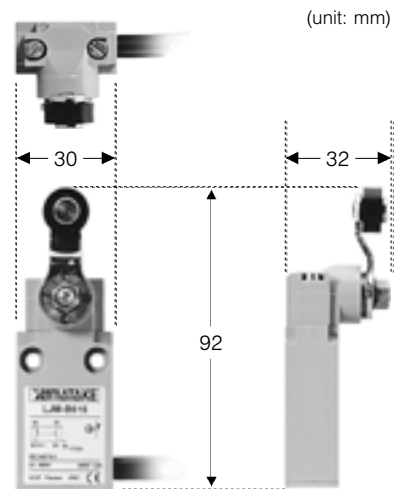

- UL/CE markings provided.
- $\odot$ contact forced open mechanism provided. (N.C. contact only)
- Compact size and high sealing ability. (IP67)
- Pre-wire cable.
- Wide operating temperature range. (-25 to +70°C)



The above photo shows the roller lever type switch.  
For details about dimensions, see relevant drawings.



### ORDER GUIDE

Actuator type	Cable length	Catalog listing
Roller plunger 	1m	<b>LJM-B502</b>
	3m	<b>LJM-B5023</b>
Roller lever 	1m	<b>LJM-B515</b>
	3m	<b>LJM-B5153</b>

### INTERNAL SWITCH

The internal switch of the **LJM** Series has the N.C./N.O. electrically independent contact (Zb) structure.

Additionally, the contact forced open structure is used to forcibly open the contact (N.C. contact only) even if the contact is fused accidentally.

As the switch is pushed in, the contact is opened forcibly.

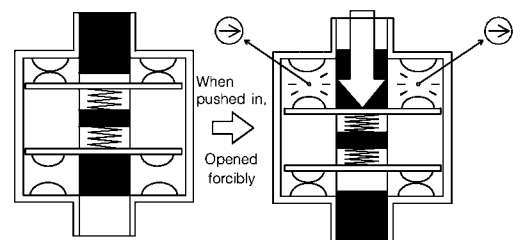

## PERFORMANCE

Standards	Conformed standards	Product related: IEC 60947-5-1, EN 60947-5-1 ⊕ Machine related: IEC 60204-1, EN 60204-1
	Approved standards	UL
Structure	Protective structure	IP67 (IEC 60529)
	Electrical shock protection	Class I (IEC 60536)
	Contamination degree of operating environment	Contamination degree 3
	Internal switch	Slow action
Electrical performance	Electrical rating	See separate Table 1.
	Dielectric strength	Between non-continuous terminals: 2,500Vac, 50/60Hz for 1min. Between each terminal and non-conducting metal part: 2,500Vac, 50/60Hz for 1min. Between each terminal and ground: 2,500Vac, 50/60Hz for 1min.
	Insulation resistance	100MΩ or more (by 500Vdc Megger)
	Rated energizing current (Ith)	6A
	Short-circuit protective device	Breaking fuse 6A type gG (gl)
	Rated insulation voltage (Ui)	400V IEC 60947-5-1, 300V UL508
	Conditional rated short-circuit current	1,000A
	Rated impulse withstanding voltage (Uimp)	4,000V
Mechanical performance	Impact resistance	250m/s <sup>2</sup> (18ms) IEC 60068-2-27
	Vibration resistance	250m/s <sup>2</sup> (10 to 500Hz) IEC 60068-2-6
	Allowable operating speed	Minimum operating speed: 0.001m/s Maximum operating speed: (30° dog is used.) <b>LJM-B502</b> □: 0.1m/s, <b>LJM-B515</b> □: 1.5m/s
Life	Mechanical life	10million operations or more
	Electrical life	4million operations (3,600 operations/hr. or less)
Environmental conditions	Operating temperature range	-25 to +70°C (No freezing allowed.)
	Operating humidity range	85%RH or less
Recommended tightening torque	Body	1.2 to 1.5N-m (M4 hexagon socket head cap bolt)

● Table 1. Electrical rating

AC-15: B300 (Ue = 240V, Ie = 1.5A) DC-13: R300 (Ue = 250V, Ie = 0.1A)
--

Category used AC-15: Solenoid load  
DC-13: Solenoid load

Ue: Rated operating voltage  
Ie: Rated operating current

## CONTACT TYPE AND WIRING

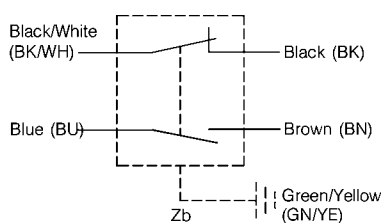

## OPERATING CHARACTERISTICS AND EXTERNAL DIMENSIONS

### ● Roller plunger type: LJM-B502

(unit: mm)

O.F. (Operating force)	(N max.)	7.5
P.T. (Pretravel)	(mm)	N.C.: 1.8 * N.O.: 3
T.T. (Total travel)	(mm)	5.25 *
P.O. (Travel to positive opening position)	(mm min.)	3.2
P.O.F. (Positive opening force)	(N min.)	37.5

\* The above Table shows the reference values.

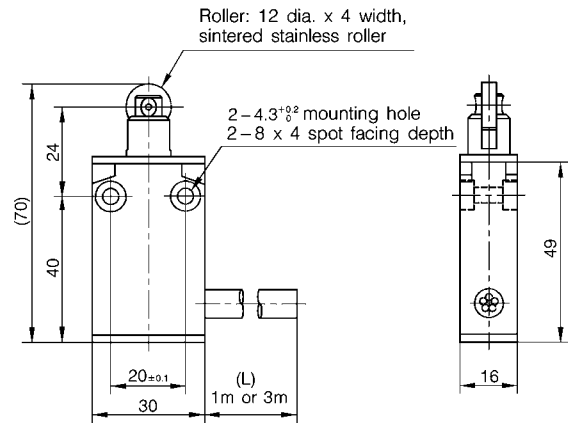
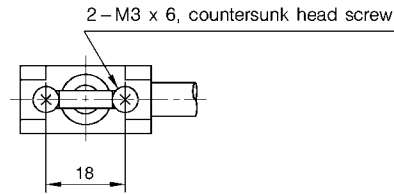

**Note 1.** The housing is made of zinc alloy, and then it is finished using blue paint.

**Note 2.** The cable is oil-resistant vinyl cabtyre round cable, 0.75mm<sup>2</sup>, 5-core wire, outside diameter: approx. 8mm, sheath color: black.

### ● Roller lever type: LJM-B515

O.F. (Operating force)	(N-m max.)	0.05
P.T. (Pretravel)	(°)	N.C.: 20 * N.O.: 40
T.T. (Total travel)	(°)	70 *
P.O. (Travel to positive opening position)	(° min.)	42
P.O.F. (Positive opening force)	(N-m min.)	0.15

\* The above Table shows the reference values.

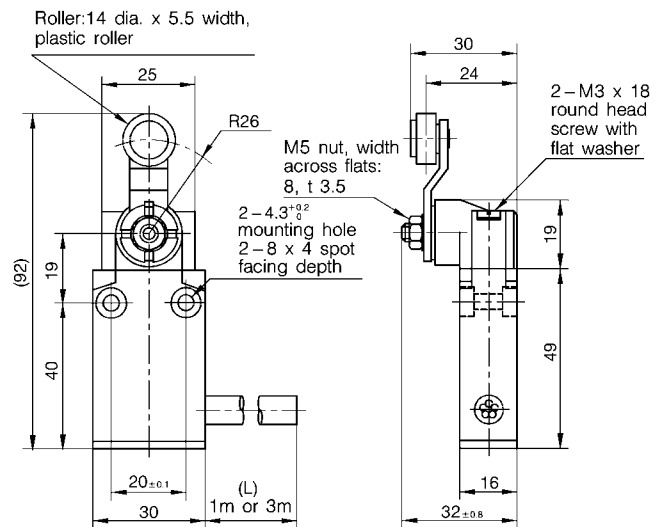
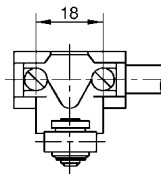

**Note 1.** The housing is made of zinc alloy, and then it is finished using blue paint.

**Note 2.** The cable is oil-resistant vinyl cabtyre round cable, 0.75mm<sup>2</sup>, 5-core wire, outside diameter: approx. 8mm, sheath color: black.

MEMO

# LJK Series

## Compact Plastic Safety Limit Switches

### FEATURES

Compact Safety Limit Switches Made of Plastic.

- UL/CE markings provided.
- $\text{☉}$  contact forced open mechanism provided. (N.C. contact only)
- Compact size.
- Wide operating temperature range. ( $-25$  to  $+70^{\circ}\text{C}$ )

(unit: mm)

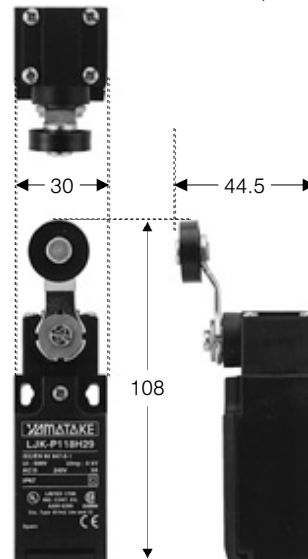



The above photo shows the roller lever type switch.  
For details about dimensions, see relevant drawings.



### ORDER GUIDE

#### ● Body

Actuator type	Internal switch mechanism	Contact type method	Catalog listing
Roller lever 	Snap action	N.C. × 1 + N.O. × 1	<b>LJK-P118H29</b>
	Slow action	N.C. × 1 + N.O. × 1	<b>LJK-P518H29</b>
Adjustable roller lever 	Snap action	N.C. × 1 + N.O. × 1	<b>LJK-P145H29</b>
	Slow action	N.C. × 1 + N.O. × 1	<b>LJK-P545H29</b>
No lever	Slow action	N.C. × 2	<b>LJK-P701H29</b>
Roller plunger 	Snap action	N.C. × 1 + N.O. × 1	<b>LJK-P102H29</b>
	Slow action	N.C. × 1 + N.O. × 1	<b>LJK-P502H29</b>
	Slow action	N.C. × 2	<b>LJK-P702H29</b>

#### ● Optional roller lever (Specially designed for LJK Series)

Actuator type (material)	Catalog listing
Roller lever (plastic)	<b>LJK-Y18</b>
Adjustable roller lever (plastic)	<b>LJK-Y45</b>

## INTERNAL SWITCH

### ● Snap action type

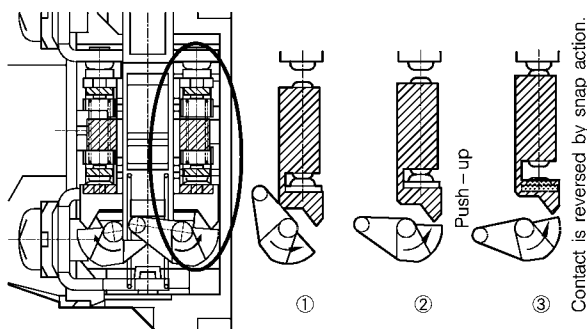

As shown in the above Fig., the cam forcibly pushes up the N.C. contact from the bottom. With this mechanism, the contact is forcibly opened even though the contact is fused.

### ● Slow action type

The internal switch of the slow action type has the N.C./N.O. electrically independent contact (Zb) structure. Additionally, the contact forced open structure is used to forcibly open the contact (N.C. contact only) even if the contact is fused accidentally.

As the switch is pushed in, the contact is opened forcibly.

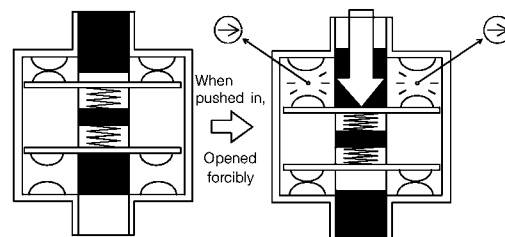

## PERFORMANCE

Standards	Conformed standards	Product related: IEC 60947-5-1, EN 60947-5-1 Machine related: IEC 60204-1, EN 60204-1
	Approved standards	UL/CSA
Structure	Protective structure	IP65
	Electrical shock protection	Class II (IEC 60536)
	Contamination degree of operating environment	Contamination degree 3
	Internal switch	(LJK-P1 ... ): Snap action, (LJK-P5 ... )(LJK-P7 ... ): Slow action
Electrical performance	Electrical rating	See separate Table 1.
	Dielectric strength	Between non-continuous terminals: 2,500Vac, 50/60Hz for 1min. Between each terminal and non-conducting metal part: 2,500Vac, 50/60Hz for 1min. Between each terminal and ground: 2,500Vac, 50/60Hz for 1min.
	Insulation resistance	100M $\Omega$ or more (by 500Vdc Megger)
	Rated energizing current (Ith)	10A
	Short-circuit protective device	Breaking fuse 10A type gG (gl)
	Rated insulation voltage (Ui)	500V IEC 60947-5-1, 300V UL 508
	Conditional rated short-circuit current	1,000A
Mechanical performance	Rated impulse withstanding voltage (Uimp)	6,000V
	Impact resistance	Incorrect operation: 400m/s <sup>2</sup> , Durability: 500m/s <sup>2</sup> (11ms) IEC 60068-2-27
	Vibration resistance	Vibration resistance: 250m/s <sup>2</sup> , (10 to 500Hz) IEC 60068-2-6
Life	Allowable operating speed	Minimum operating speed: 0.001 m/s Maximum operating speed: (30° dog is used.) Roller lever type: 1.5 m/s Roller plunger type: 0.3 m/s
	Mechanical life	10million operations
	Electrical life	Snap action: 300,000 operations, Slow action: 400,000 operations
Environment	Operating temperature range	-25 to +70°C (No freezing allowed.)
	Operating humidity range	85%RH or less
	Storage temperature range	-40 to +70°C
Recommended tightening torque	Body	Body: 0.5 to 0.7N-m (M4) Head: 0.2 to 0.4N-m (M3 round head screw) Cover: 0.2 to 0.4N-m (M3 round head screw) Terminal: 0.4 to 0.6 N-m (M3.5 round head screw) Lever: 1.3 to 1.7 N-m (M4 round head screw)

### ● Table 1. Electrical rating

AC-15: A300 (Ue = 240V, Ie = 3A)  
DC-13: Q300 (Ue = 250V, Ie = 0.27A)

Category used AC-15: Solenoid load  
DC-13: Solenoid load  
Ue: Rated operating voltage  
Ie: Rated operating current

## EXTERNAL DIMENSIONS, OPERATING CHARACTERISTICS, AND CIRCUIT DIAGRAMS

● Roller lever type: **LJK-P118H29**, **LJK-P518H29**

● No lever type: **LJK-P701H29**

(unit: mm)

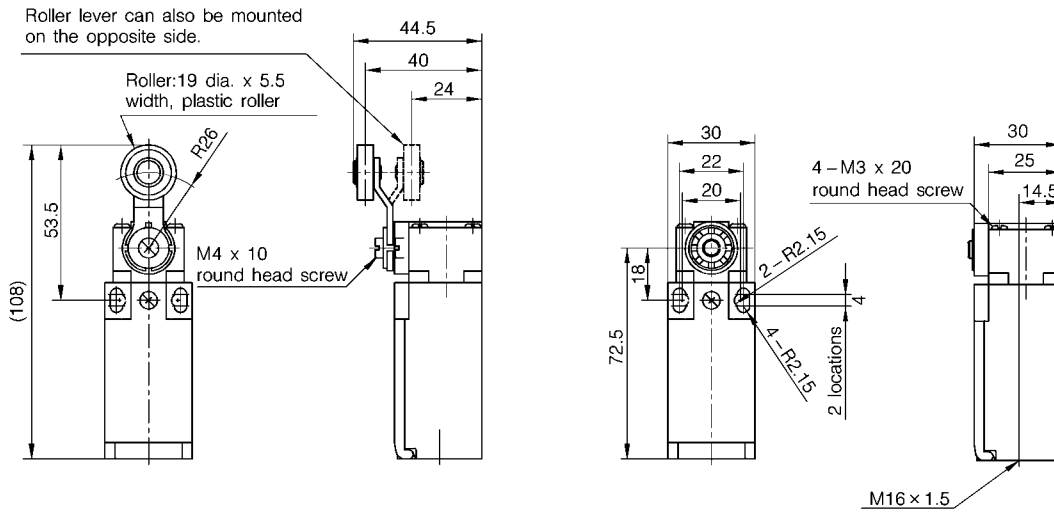

Operating characteristics by lever rotational angle	LJK-P118H29	LJK-P518H29	LJK-P701H29 (Note)
O.F. (Maximum operating force needed for N.C. operation) (N-m)	0.1	0.1	0.1
P.O. (Minimum travel to positive opening position) (°)	60	46	46
P.O.F. (Minimum force of positive opening) (N-m)	0.25	0.25	0.25
PT1 (Pretravel for N.C. operation) (°)	(25)	(25)	(25)
PT2 (Pretravel for N.O. operation) (°)	—	(35)	—
M.D. (Minimum movement differential) (°)	(12)	—	—
T.T. (Total travel) (°)	(70)	(70)	(70)

Note: The above Table shows the values obtained when the lever **LJK-Y18** is mounted.

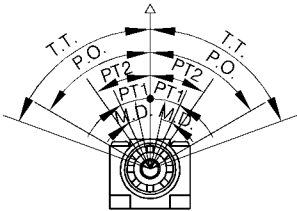

Catalog listing	LJK-P118H29	LJK-P518H29	LJK-P701H29
Operating characteristics by dog operation ■ : Contact close □ : Contact open (P) = Minimum travel to positive opening position			
Circuit diagram			

● Adjustable roller lever type: **LJK-P145H29**, **LJK-P545H29**

(unit: mm)

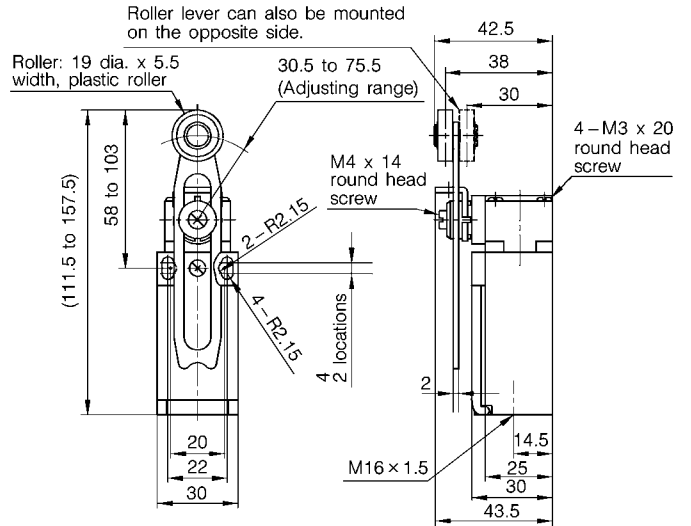

Operating characteristics by lever rotational angle	LJK-P145H29	LJK-P545H29
O.F. (Maximum operating force needed for N.C. operation) (N-m)	0.1	0.1
P.O. (Minimum travel to positive opening position) (°)	60	46
P.O.F. (Minimum force of positive opening) (N-m)	(0.25)	(0.25)
PT1 (Pretravel for N.C. operation) (°)	(25)	(25)
PT2 (Pretravel for N.O. operation) (°)	—	(35)
M.D. (Minimum movement differential) (°)	(12)	—
T.T. (Total travel) (°)	(70)	(70)

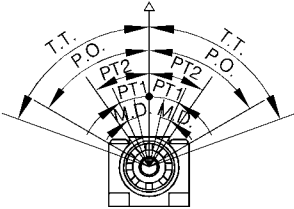

Catalog listing	LJK-P145H29	LJK-P545H29
Operating characteristics by dog operation ■ : Contact close □ : Contact open (P) = Minimum travel to positive opening position		
Circuit diagram		

● Roller plunger type: LJK-P102H29, LJK-P502H29, LJK-P702H29

(unit: mm)

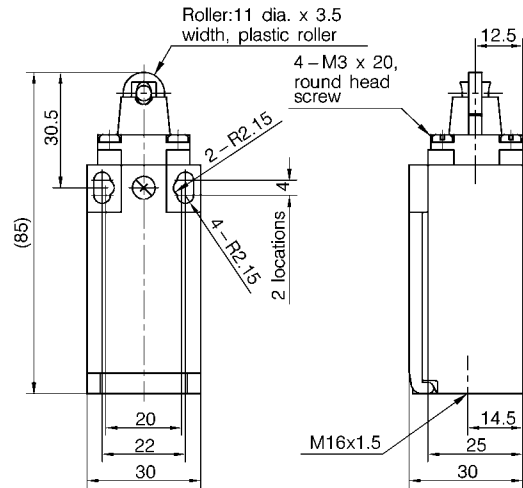

Operating characteristics by vertical operation	LJK-P102H29	LJK-P502H29	LJK-P702H29
O.F. (Maximum operating force needed for N.C. operation) (N)	15	15	15
P.O. (Minimum travel to positive opening position) (mm)	4.5	3.2	3.2
P.O.F. (Minimum force of positive opening) (N)	45	45	45
PT1 (Pretravel for N.C. operation) (mm)	(1.8)	(1.8)	(1.8)
PT2 (Pretravel for N.O. operation) (mm)	—	(3)	—
M.D. (Minimum movement differential) (mm)	(0.9)	—	—
T.T. (Total travel) (mm)	(5)	(5)	(5)

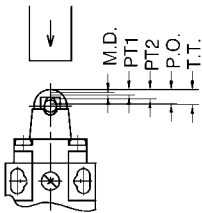

Catalog listing	LJK-P102H29	LJK-P502H29	LJK-P702H29
Operating characteristics by dog operation ■ : Contact close □ : Contact open (P) = Minimum travel to positive opening position			
Circuit diagram			

● Lever (Specially designed for LJK-P Series)  
LJK-Y18

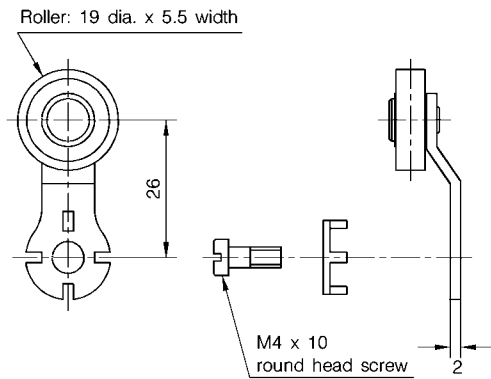

LJK-Y45

(unit: mm)

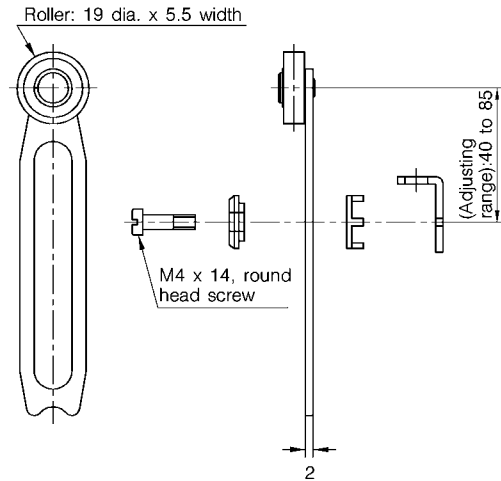

**HANDLING PRECAUTIONS**

● **Mounting the switch**

- Always tighten each part of the safety switch with the recommended tightening torque stated in the product specification. If any part is tightened excessively, this might cause damage to the screw and/or other parts.
- Mount the dog so that no force is directly applied to the actuator in the free state.
- Do not use any silicon glue or grease including silicon. Doing so might result in faulty electrical continuity.

● **Wiring**

- Do not perform the wiring work with the power turned ON. Doing so might cause an electrical shock or the machine to be operated suddenly.

● **Adjustment**

- Do not apply any excessive force (force 5 times larger than O.F.) to the actuator exceeding the operation limit position. Doing so might cause the switch to break.
- Adjust the actuator motion so that it exceeds the specified P.O. (travel to positive opening position) value and it is the operation limit position or less at the same time.

● **Environment**

- Do not use the switch in an environment where strong acid or alkaline is directly splashed onto it.

# LJS-A Series

## Die-cast Safety Interlock Switches

### FEATURES

Solid Safety Interlock Switches Made of Die-cast.

- *UL/CSA/CE markings provided.*
- *☞contact forced open mechanism provided. (N.C. contact only)*
- *High sealing ability. (IP67)*

(unit: mm)

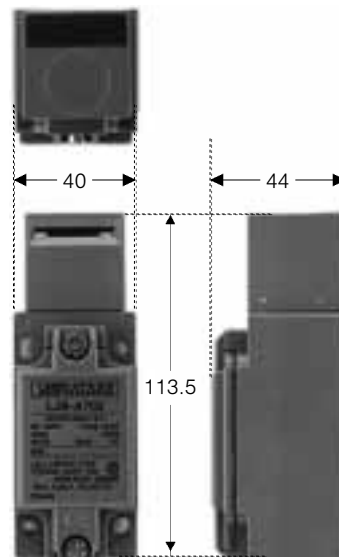



For details about dimensions, see relevant drawings.

### ORDER GUIDE

#### • Body

Contact type	Catalog listing
N.C. × 1 + N.O. × 2	<b>LJS-A502</b>
N.C. × 2 + N.O. × 1	<b>LJS-A702</b>

#### • Tongued key

Shape	Catalog listing
Straight type 	<b>LJS-Z01</b>
Right angle type 	<b>LJS-Z02</b>
Adjustable type 	<b>LJS-Z03</b>

### INTERNAL SWITCH

The internal switch of the **LJS-A** Series has the N.C./N.O. electrically independent contact (Zb) structure.

Additionally, the contact forced open structure is used to forcibly open the contact (N.C. contact only) even if the contact is fused accidentally.

As the switch is pushed in, the contact is opened forcibly.

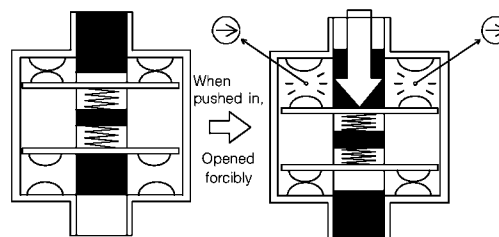

## PERFORMANCE

Standards	Conformed standards	Product related: IEC 60947-5-1, EN 60947-5-1 Machine related: IEC 60204-1, EN 60204-1, EN 1088
	Approved standards	UL/CSA
Structure	Protective structure	IP67 (IEC 60529)
	Electrical shock protection	class I (IEC 60536)
	Contamination degree of operating environment	Contamination degree 3
Electrical performance	Electrical rating	See separate Table 1.
	Rated energizing current (Ith)	10A
	Short-circuit protective device	Breaking fuse 10A type gG (gl)
	Rated insulation voltage (Ui)	500V IEC 60947-1, 300V UL508
	Conditional rated short-circuit current	1,000A
Mechanical performance	Rated impulse withstanding voltage (Uimp)	6,000V
	Impact resistance	100m/s <sup>2</sup> (11ms) IEC 60068-2-27
	Vibration resistance	50m/s <sup>2</sup> (10 to 500Hz) IEC 60068-2-6
	Minimum operating speed	0.01m/s
Life	Maximum operating speed	0.5m/s
	Mechanical life	1,000,000 operations or more
Environmental conditions	Electrical life	500,000 operations or more
	Operating temperature range	-25 to +70°C (No freezing allowed.)
	Storage temperature range	-40 to +70°C
Recommended tightening torque	Operating humidity range	85%RH or less
	Body	5 to 6N-m (M5 hexagon socket head cap bolt)
	Cover	2.7 to 3.0N-m (M5 flat fillister head screw) 1.3 to 1.7N-m (M4 flat fillister head screw)
	Terminal	0.8N-m (M3 binding machine screw)

• Installation Instructions No.: CP-UM-5282E

### • Table 1. Electrical rating

AC-15: A300 (Ue=240V, Ie=3A or Ue=120V, Ie=6A)  
DC-13: Q300 (Ue=250V, Ie=0.27A or Ue=125V, Ie=0.55A)

Category used AC-15: Solenoid load

DC-13: Solenoid load

Ue: Rated operating voltage

Ie: Rated operating current

## CONTACT OPERATION

Catalog listing	LJS-A502	LJS-A702
<p>■ : Contact close</p> <p>□ : Contact open</p> <p>▨ : Transient state</p>	<p>Tongued key insertion (NORMAL) state</p>	<p>Tongued key insertion (NORMAL) state</p>
Circuit diagram		

## OPERATING CHARACTERISTICS AND EXTERNAL DIMENSIONS

### • Body

#### • LJS-A□02

(unit: mm)

Tongued key removal strength	20N
Forced opening force (Min.)	20N

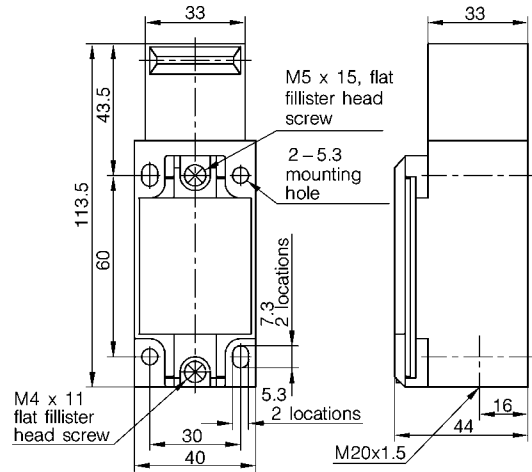

### • Tongued key LJS-Z01

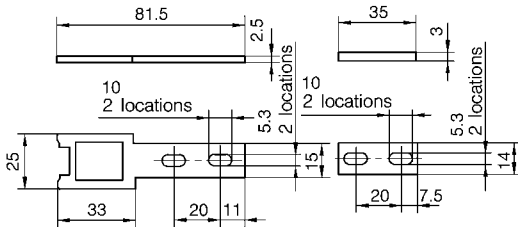

### LJS-Z02

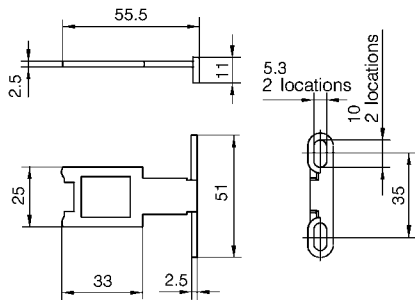

### LJS-Z03

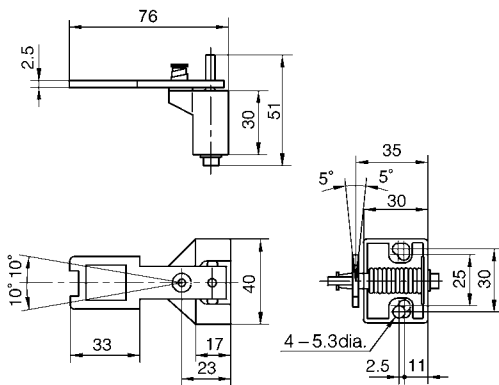

### • Diagram of tongued key position

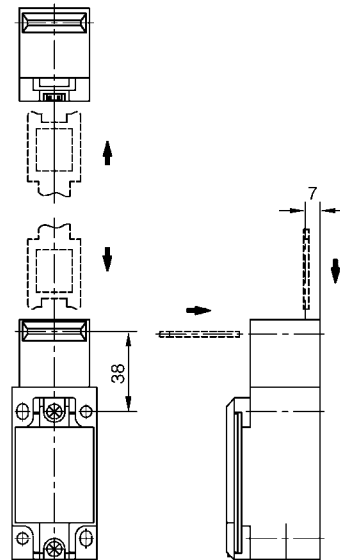

### • Diagram of tongued key insertion position

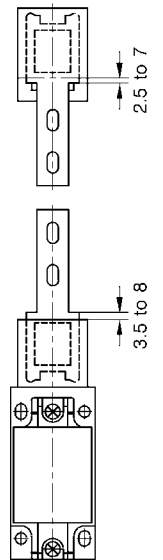

● Actuation radius of tongued key  
**LJS-Z01/Z02**

(unit: mm)

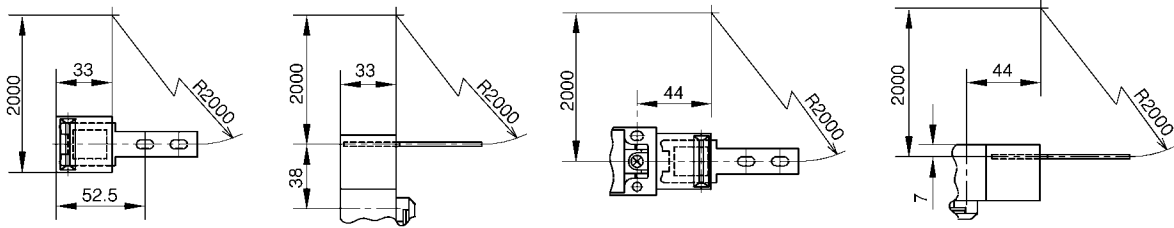

**LJS-Z03**

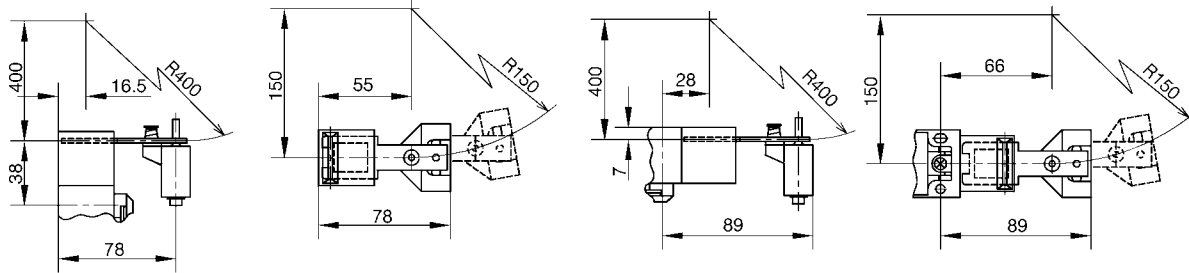

**HANDLING PRECAUTIONS**

● Mounting the switch

- Always tighten each part of the safety switch with the recommended tightening torque stated in the product specification. If any part is tightened excessively, this might cause damage to the screw and/or other parts. Additionally, insufficient tightening may lead to lowering of various characteristics, such as switch sealing ability.
- Regardless of the door type, do not use the safety switch for the door stopper.  
 A mechanical door stopper is installed at the end of the door so that any excessive force is not applied to the safety switch.
- Do not apply any excessive impact to the safety switch by opening or closing the door carelessly. If any excessive impact is applied to the switch, this might cause the switch to malfunction.
- When the safety switch is operated in a place where a large amount of foreign matter or dust exists, appropriate measures, such as protective cover are taken to prevent foreign matter or dust from entering the safety switch through the tongued key insertion port. If a large amount of foreign matter or dust enters the safety switch, this may affect the mechanical part, resulting in malfunction.

● Tongued key

- Do not use any tongued key other than that specified.  
 Operation with a tongued key other than that specified might cause the switch to break.
- Mount the tongued key in a place where it is not in contact with the operator's body when opening or closing the door. Failure to do so might cause personal injury.

To properly and safely operate the switch, see also the separate Installation Instructions, "Safety Interlock Switch **LJS-A Series**", (Installation Instructions No.: **CP-UM-5282E**).

# LJS-PA Series

## Plastic Safety Interlock Switches

### FEATURES

Safety Interlock Switches Made of Plastic.

- UL/CSA/CE markings provided.
- $\text{\textcircled{C}}$ contact forced open mechanism provided. (N.C. contact only)
- Compact size and high sealing ability. (IP67)
- Double-insulation structure with plastic housing. (No grounding line connection required.)
- Wide operating temperature range. ( $-25$  to  $+70^{\circ}\text{C}$ )

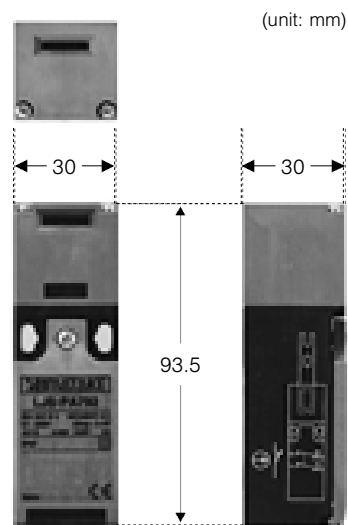

For details about dimensions, see relevant drawings.





### ORDER GUIDE

#### • Body

Contact type	Catalog listing
N.C. $\times$ 1 + N.O. $\times$ 1	<b>LJS-PA592</b>
N.C. $\times$ 2	<b>LJS-PA792</b>

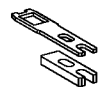
#### • Tongued key

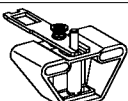
Shape	Catalog listing
Straight type 	<b>LJS-Z11</b>
Right angle type 	<b>LJS-Z12</b>
Adjustable type 	<b>LJS-Z13</b>

### INTERNAL SWITCH

The internal switch of the **LJS-PA** Series has the N.C./N.O. electrically independent contact (Zb) structure.

Additionally, the contact forced open structure is used to forcibly open the contact (N.C. contact only) even if the contact is fused accidentally.

As the switch is pushed in, the contact is opened forcibly.

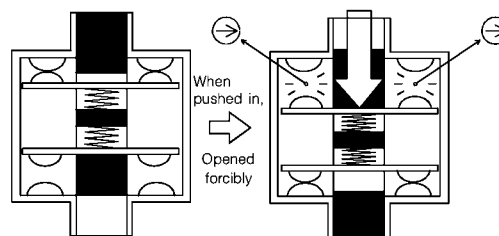

## PERFORMANCE

Standards	Conformed standards	Product related: IEC 60947-5-1, EN 60947-5-1 Machine related: IEC 60204-1, EN 60204-1, EN 1088
	Approved standards	UL/CSA
Structure	Protective structure	IP67 (JIS C 0920) (IEC 60529)
	Electrical shock protection	class II (IEC 60536)
	Internal switch	Slow action
Electrical performance	Electrical rating	See separate Table 1.
	Rated energizing current (Ith)	10A
	Short-circuit protective device	Breaking fuse 10A type gG (gl)
	Rated insulation voltage (Ui)	500V IEC 60947-1, 300V UL/CSA
	Conditional rated short-circuit current	1,000A
	Rated impulse withstanding voltage (Uimp)	6,000V
Mechanical performance	Impact resistance	100m/s <sup>2</sup> (11ms) IEC 60068-2-27
	Vibration resistance	50m/s <sup>2</sup> (10 to 500Hz) IEC 60068-2-6
	Tongued key operating speed	0.01m/s to 0.5m/s
	Mechanical operation frequency	10 operations/min.
Life	Mechanical life	1,000,000 operations or more
	Electrical life	400,000 operations or more
Environmental conditions	Operating temperature range	-25 to +70°C (No freezing allowed.)
	Operating humidity range	85% RH or less
Recommended tightening torque	Body	0.49 to 0.69N-m (M4 screw)
	Terminal	0.8N-m (M3.5 binding machine screw)
	Cover	0.5N-m (M3 round head screw)
	Head	0.5N-m (M3 round head screw)

• Installation Instructions No.: CP-UM-5215E

### • Table 1. Electrical rating

AC-15: A300  
(U<sub>e</sub> = 240V, I<sub>e</sub> = 3A or U<sub>e</sub> = 120V, I<sub>e</sub> = 6A)  
DC-13: Q300  
(U<sub>e</sub> = 250V, I<sub>e</sub> = 0.27A or U<sub>e</sub> = 125V, I<sub>e</sub> = 0.55A)

Category used AC-15: Solenoid load

DC-13: Solenoid load

U<sub>e</sub>: Rated operating voltage

I<sub>e</sub>: Rated operating current

## CONTACT OPERATION

Catalog listing	LJS-PA592	LJS-PA792
<p>  : Contact close   : Contact open   : Transient state         </p>	<p>Tongued key insertion (NORMAL) state</p>	<p>Tongued key insertion (NORMAL) state</p>
Circuit diagram		

## OPERATING CHARACTERISTICS AND EXTERNAL DIMENSIONS

### • Body

Tongued key removal strength	10N
Forced opening force (Min.)	15N

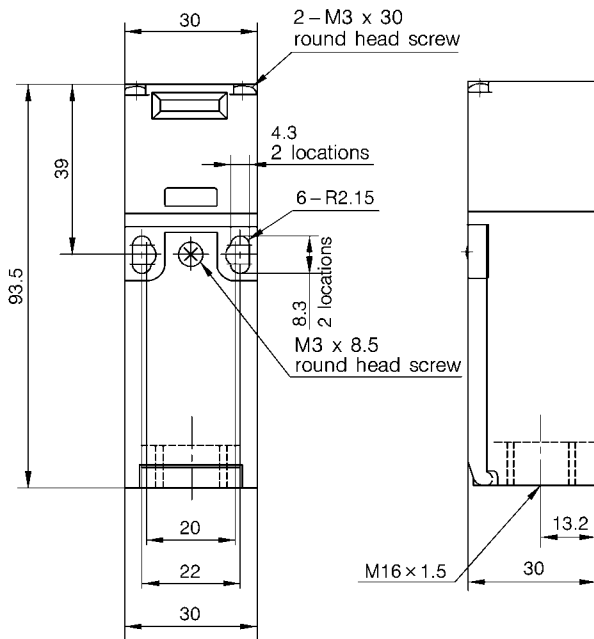
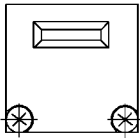

### • Tongued key

(unit: mm)

#### LJS-Z11

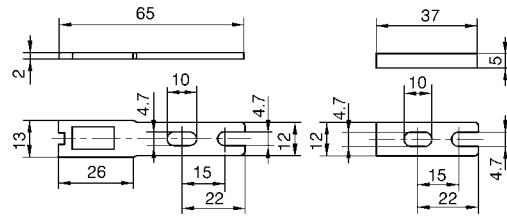

#### LJS-Z12

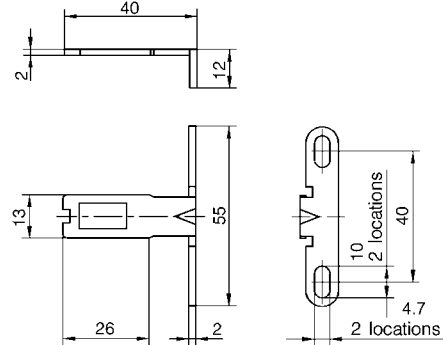

#### LJS-Z13

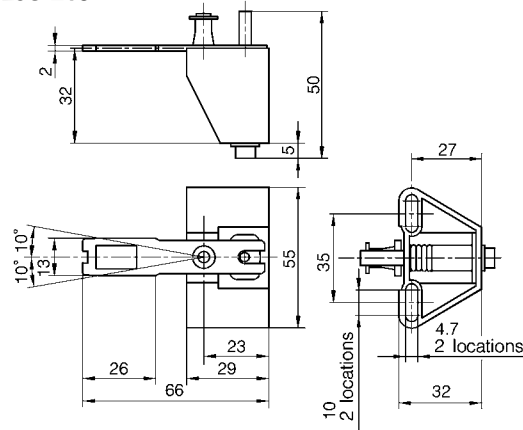

## CIRCUIT EXAMPLES

- Example of circuit in category 1 of EN 954-1  
N.C. + N.O.

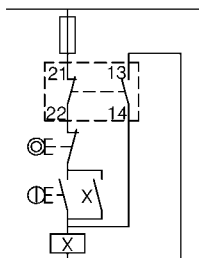

- Example of circuit in category 3 of EN 954-1  
N.C. + N.O.

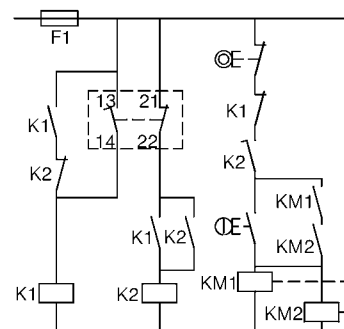

The reset is activated when the tongued key is removed, and then it is inserted.

**Note:** For mechanical/electrical redundancy, add another switch with the contact forced open mechanism.

● Diagram of tongued key position

● Diagram of tongued key insertion position

(unit: mm)

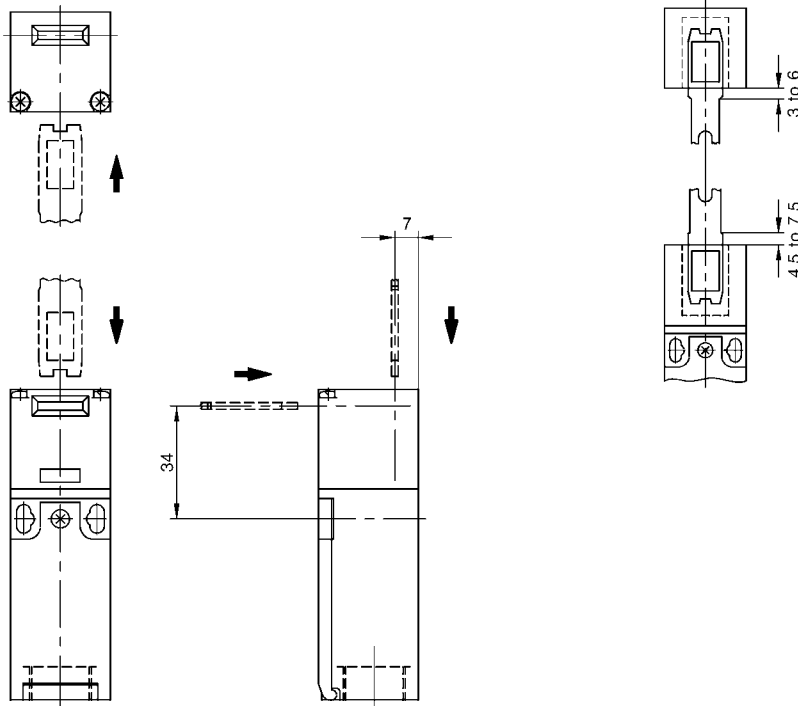

● Actuation radius of tongued key  
LJS-Z11/Z12

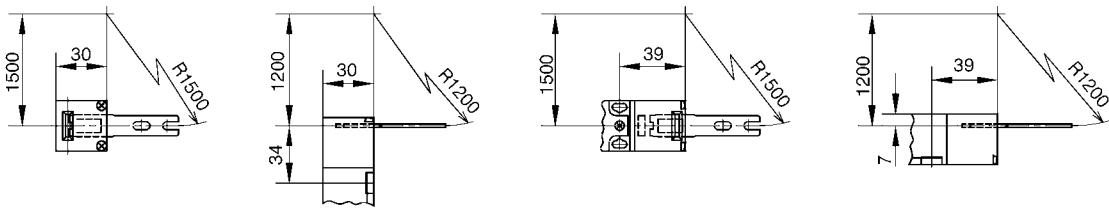

LJS-Z13

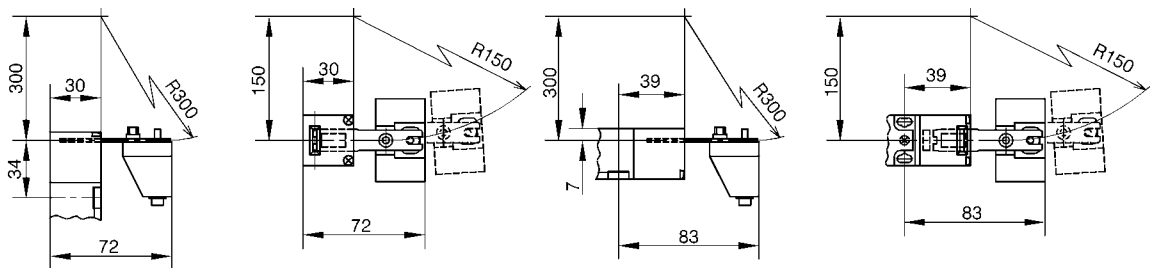

**HANDLING PRECAUTIONS**

● Mounting the switch

To properly and safely operate the switch, see also the separate Installation Instructions, "Safety Interlock Switch **LJS-PA Series**", (Installation Instructions No.: CP-UM-5215E).

- Always tighten each part of the safety switch with the recommended tightening torque stated in the product specification. If any part is tightened excessively, this might cause damage to the screw and/or other parts. Additionally, insufficient tightening may lead to lowering of various characteristics, such as switch sealing ability.

# LJH Series Compact Plastic Safety Interlock Switches

## FEATURES

Safety Interlock Switches with Compact Size Made of Plastic.

- $\ominus$ contact forced open mechanism provided. (N.C. contact only)
- Safety interlock switch conforming to EN 60947-5-1, UL 508, and CSA 22.2.14.
- Compact size (78 × 30 × 15mm) ensures installation in any place.
- Special key can be inserted even in the vertical and horizontal directions.
- Pre-wire cable.

## APPLICATIONS

- Machine tools
  - Semiconductor manufacturing systems
  - Electronics component inserting machines, such as chip mounters
  - Food processing machines (filling machines and packing machines)
  - General industrial machines
  - Printing machines
- For safety doors of above machines and systems
- Fence opening of engine machining, welding, and assembly lines

(unit: mm)

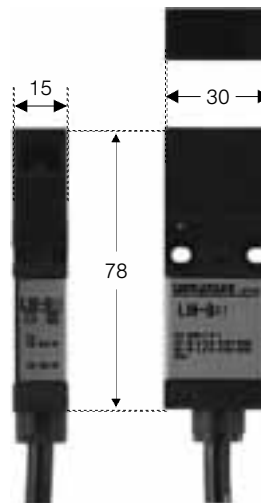

For details about dimensions, see relevant drawings.

## ORDER GUIDE

### • Body

Cable length	Contact type	Catalog listing
1m	N.C. × 1 + N.O. × 1	<b>LJH-D11</b>
3m		<b>LJH-D13</b>
5m		<b>LJH-D15</b>
1m	N.C. × 2	<b>LJH-D21</b>
3m		<b>LJH-D23</b>
5m		<b>LJH-D25</b>

### • Tongued key

Shape	Catalog listing
Straight type	<b>LJH-X1</b>
L type	<b>LJH-X2</b>
Horizontal/Vertical adjustment type (counterclockwise)	<b>LJH-X5</b>
Horizontal/Vertical adjustment type (clockwise)	<b>LJH-X6</b>



## INTERNAL SWITCH

The internal switch of the **LJH** Series has the N.C./N.O. electrically independent contact (Zb) structure.

Additionally, the contact forced open structure is used to forcibly open the contact (N.C. contact only) even if the contact is fused accidentally.

As the switch is pushed in, the contact is opened forcibly.

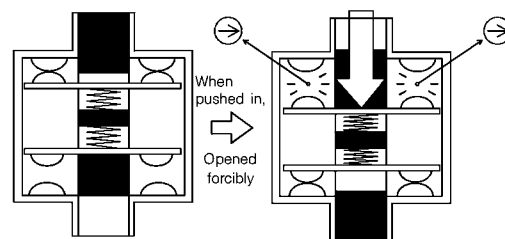

## PERFORMANCE

Standards	Conformed standards	Product related: IEC 60947-5-1 Machine related: IEC 60204-1, EN 60204-1, ISO 14119, EN 1088
	Approved standards	GS-ET-15 (BG)/UL/CSA
Structure	Protective structure	IP67 (IEC 60529)
	Electrical shock protection	Class II
	Contamination degree of operating environment	Contamination degree 3
	Internal switch	Slow action
Electrical performance	Electrical rating	See separate Table 1.
	Insulation resistance	Between conducting part and non-conducting part: 100M $\Omega$ or more (by 500Vdc Megger) Between different pole conducting parts: 100M $\Omega$ or more (by 500Vdc Megger)
	Contact resistance	300m $\Omega$ or less. (Initial value, 1m cable)
	Rated energizing current (Ith)	2.5A
	Short-circuit protective device	Breaking fuse, 250V/10A
	Rated insulation voltage (Ui)	300V
	Conditional rated short-circuit current	50A
	Rated impulse withstanding voltage (Uimp)	4,000V
Mechanical performance	Impact resistance	Incorrect operation: 300m/s <sup>2</sup> Durability: 1,000m/s <sup>2</sup>
	Vibration resistance	Incorrect operation: 5 to 55Hz, Peak amplitude: 0.5mm or more Durability: 30Hz, Peak amplitude: 1.5mm or more
	Tongued key operating speed	0.05 to 1.0m/s
	Direct circuit operating stroke	8mm or more
	Direct circuit operating force	60N or more (Tongued key removal)
	Operating frequency	20 operations/min.
Life	Mechanical life	1,000,000 operations or more, operating frequency: 20 operations/min.
	Electrical life	100,000 operations or more, operating frequency: 20 operations/min.
Environmental conditions	Operating temperature range	- 25 to +70°C (No freezing allowed.)
	Storage temperature range	- 40 to +80°C (No freezing allowed.)
	Operating humidity range	45 to 85%RH (No dew condensation allowed.)
Recommended tightening torque	Boby	1.0 to 1.5N-m (M4 hexagon socket head cap bolt)

- Installation Instructions No.: CP-UM-5278E (**LJH-D**), CP-UM-5279E (**LJH-X**)

- Table 1.

Rated operating voltage (Ue)		30V	125V	250V
AC	Resistive load (AC-12)	–	2.5 A	1.5 A
	Inductive load (AC-15)	–	1.5 A	0.75A
DC	Resistive load (DC-12)	2.5A	1.1 A	0.55A
	Inductive load (DC-13)	2.3A	0.55A	0.27A

## CONTACT OPERATION

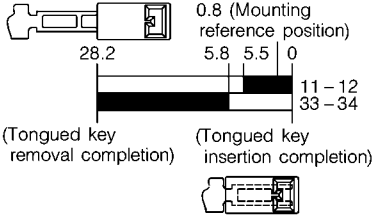
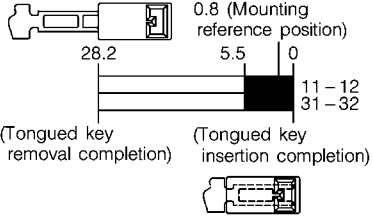
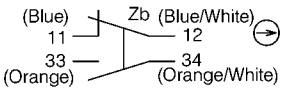
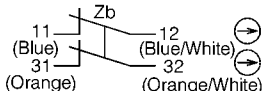
Catalog listing	LJH-D1□	LJH-D2□
Contact operation diagram (Stroke: mm)  : Electrical continuity		
Circuit diagram		

## EXTERNAL DIMENSIONS

### ● Switch body LJH-D□

(unit: mm)

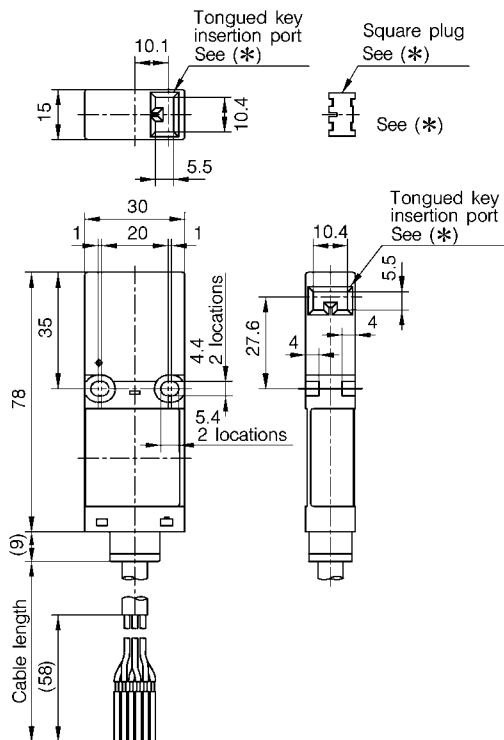

Seal the unused port for tongued key with a square plug.

• Special tongued key

**LJH-X1**

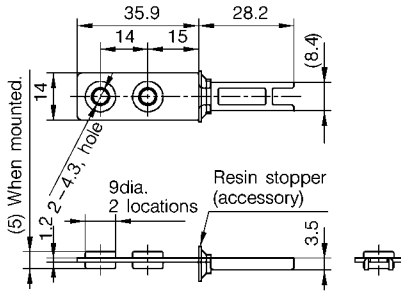

**LJH-X2**

(unit: mm)

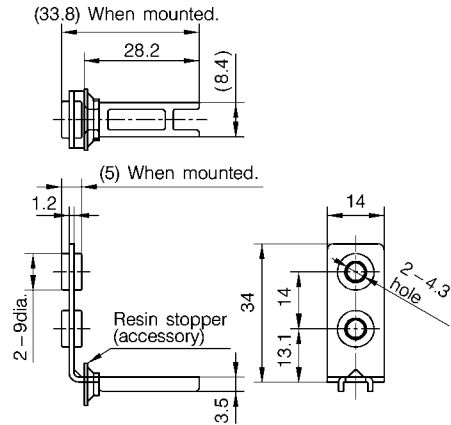

**LJH-X5**

• Horizontal adjustment type

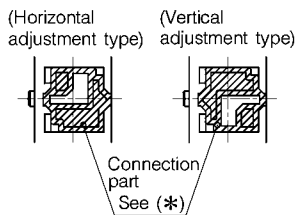
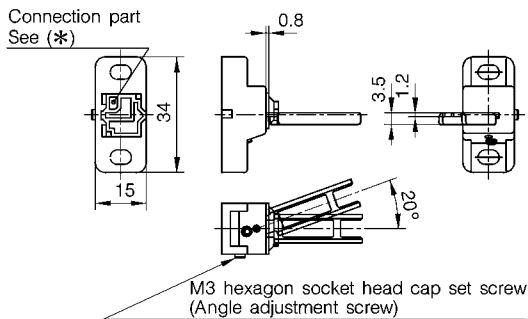

• Vertical adjustment

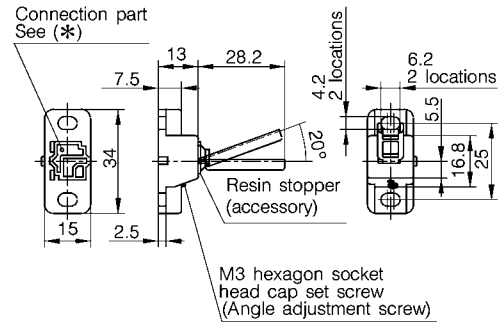

For the movable direction of the horizontal/vertical adjustment type tongued key, the movable direction of the tongued key (horizontal/vertical adjustment type) can be changed by changing the mounting direction of the connection part (white part) on the back. Mount the connection part corresponding to the customer's application.

(See the Fig. on the left.)

Additionally, carefully handle the connection part so that it is not lost. If the connection part is lost, the switch does not function correctly.

**LJH-X6**

The difference between **LJH-X6** and **LJH-X5** is that the assembly orientation of the metallic part at the top of the tongued key is reversed 180°.

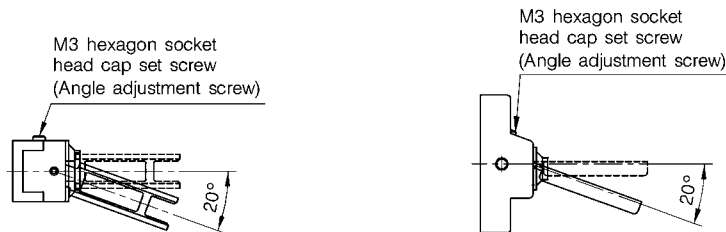

● Minimum radius of rotary door

• When the fixed type actuator (L type: Tongued key model **LJH-X2**) is used:

(unit: mm)

(1) The center of the rotary door is used as the reference for the tongued key mounting surface.

(2) The center of the rotary door is used as the reference for the safety switch contact surface.



• When the horizontal/vertical adjustment type actuator (tongued key model **LJH-X5** or **LJH-X6**) is used:

(1) The center of the rotary door is used as the reference for the tongued key mounting surface.

• Horizontal adjustment type

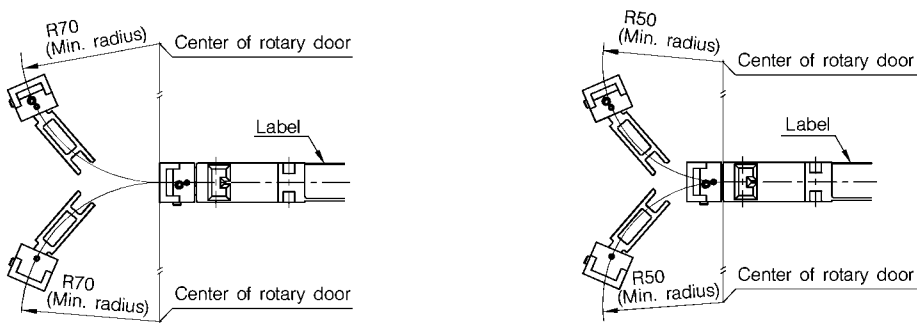

(2) The center of the rotary door is used as the reference for the safety switch contact surface.

• Vertical adjustment type

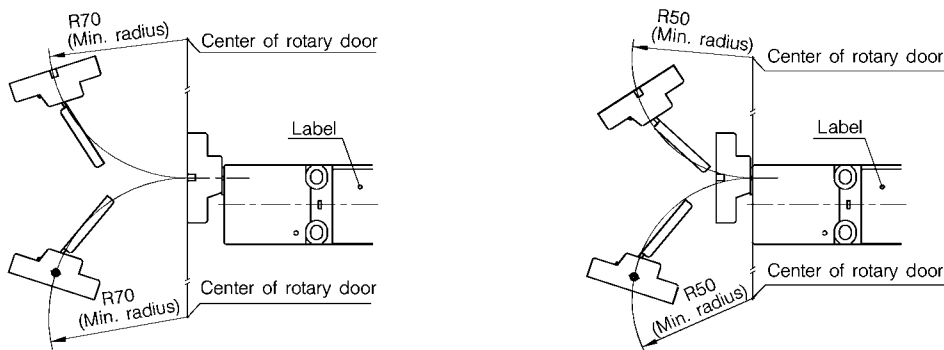

● **Adjusting the angle of the horizontal/vertical adjustment type tongued key**

• The angle of the tongued key can be adjusted by setting the angle adjustment screw (M3 hexagon socket head cap bolt). For details, see page 2/2 of the product specification AD53840.

Angle adjusting range: 0 to 20°C

• As the angle of the tongued key becomes larger, the applicable radius of the rotary door becomes smaller. After the tongued key has been mounted, open the door and make the adjustment so that the top of the tongued key is inserted into the tongued key insertion port of the safety switch.

• After the angle of the tongued key has been adjusted, take appropriate loose prevention measures, such as locking of the angle adjustment screw.

● **Diagrams of tongued key positions**

**Straight type tongued key model**  
: **LJH-X1**

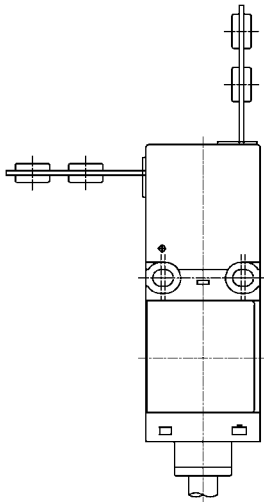

**L-type tongued key model**  
: **LJH-X2**

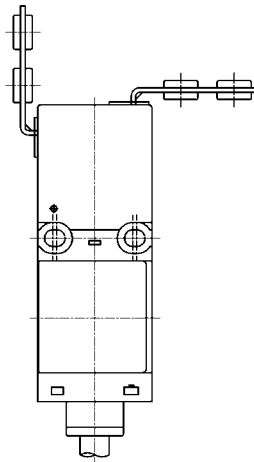

**Horizontal/Vertical adjustment type tongued key model**  
: **LJH-X5, LJH-X6**

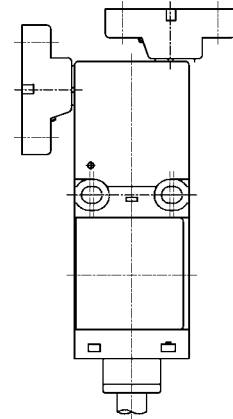

**Note 1.** The resin stopper is a part intended for positioning of the tongued key. This stopper should be removed after the tongued key position has been locked.

**Note 2.** An appropriate tongued key is selected from **LJH-X1, LJH-X2, LJH-X5, and LJH-X6**.

**HANDLING PRECAUTIONS**

● **Mounting**

- Always tighten each part of the safety switch with the recommended tightening torque stated in the product specification. If any part is tightened excessively, this might cause damage to the screw and/or other parts. Additionally, insufficient tightening may lead to lowering of various characteristics, such as switch sealing ability.
- Regardless of the door type, do not use the safety switch for the door stopper.  
A mechanical door stopper is installed at the end of the door so that any excessive force is not applied to the safety switch.
- Do not apply any excessive impact to the safety switch by opening or closing the door carelessly. If any excessive impact is applied to the switch, this might cause the switch to malfunction.
- When the safety switch is operated in a place where a large amount of foreign matter or dust exists, appropriate measures, such as protective cover are taken to prevent foreign matter or dust from entering the safety switch through the tongued key insertion port. If a large amount of foreign matter or dust enters the safety switch, this may affect the mechanical part, resulting in malfunction.

● **Tongued key**

- Do not use any tongued key other than that specified.  
Operation with a tongued key other than that specified might cause the switch to break.
- Mount the tongued key in a place where it is not in contact with the operator's body when opening or closing the door. Failure to do so might cause personal injury.

To properly and safely operate the switch, see also the separate User's Manuals, "Safety Switch **LJH-D Series**", (Installation Instructions No.: **CP-UM-5278E**).

# LJS-E Series

## Die-cast Safety Interlock Switches with Solenoid Lock

### FEATURES

Safety Interlock Switches with Solenoid Lock Made of Die-cast.

- UL/CSA/CE markings provided.
- $\text{E}$ contact forced open mechanism provided. (N.C. contact only)
- High sealing ability. (IP67)
- Safety interlock switch made of die-cast.
- Indicator provided as standard accessory.

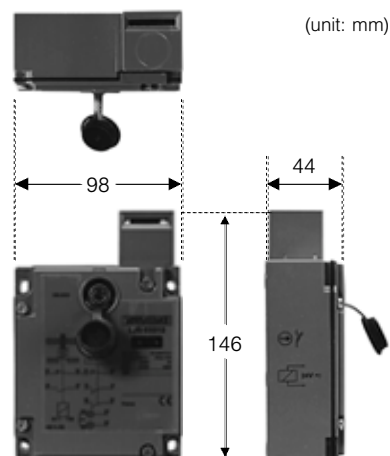



For details about dimensions, see relevant drawings.

### ORDER GUIDE

#### • Body

Contact type	Lock method	Catalog listing
N.C. × 2 + N.O. × 1	Locked when solenoid is not energized.	<b>LJS-E7312</b>
N.C. × 1 + N.O. × 2		<b>LJS-E5312</b>
N.C. × 2 + N.O. × 1	Locked when solenoid is energized.	<b>LJS-E7512</b>
N.C. × 1 + N.O. × 2		<b>LJS-E5512</b>

#### • Tongued key

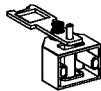
Shape	Catalog listing
Straight type 	<b>LJS-Z01</b>
Right angle type 	<b>LJS-Z02</b>
Adjustable type 	<b>LJS-Z03</b>

## INTERNAL SWITCH

The internal switch of the **LJS-E** Series has the N.C./N.O. electrically independent contact (Zb) structure.

Additionally, the contact forced open structure is used to forcibly open the contact (N.C. contact only) even if the contact is fused accidentally.

As the switch is pushed in, the contact is opened forcibly.

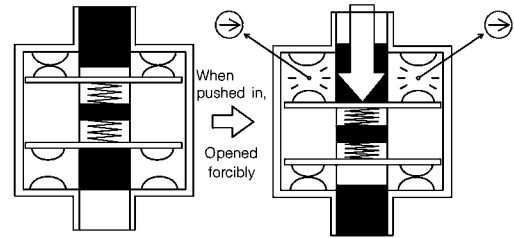

## PERFORMANCE

Catalog listing		LJS-E□312	LJS-E□512	
Standards	Conformed standards	Product related: IEC 60947-5-1, EN 60947-5-1 Machine related: IEC 60204-1, EN 60204-1, EN 1088		
	Approved standards	UL/CSA		
Structure	Protective structure	IP67 (JIS C 0920), (IEC 60529)		
	Electrical shock protection	class I (IEC 60536)		
	Internal switch	Slow action		
	Lock method	Locked when the solenoid is not energized.	Locked when the solenoid is energized.	
Electrical performance	Body	Electrical rating	AC-15: 24/48V 6A DC-13: 24/48V 0.55A	
		Rated energizing current (Ith)	6A	
		Short-circuit protective device	Breaking fuse 10A type gG (gl)	
		Rated insulation voltage (Ui)	500V IEC 60947-1, 300V UL 508/CSA	
		Conditional rated short-circuit current	1,000A	
		Rated impulse withstanding voltage (Uimp)	4,000V	
	Solenoid coil	Load factor	100%	
		Rated insulation voltage	AC/DC 24V	
		Allowable voltage variation range	-20%, +10%	
		Electrical life	Average life: 20,000hrs.	
		Power consumption	Rush: 10VA, Retention: 10VA	
	LED indicator	Rated insulation voltage	50V	
		Rated current	7mA (1 unit)	
		Rated voltage	AC/DC 24/48V	
		Allowable voltage variation	AC/DC 20 to 52V	
		Electrical life	Average life: 100,000hrs.	
	Mechanical performance	Impact resistance	100m/s <sup>2</sup> (11ms) IEC 60068-2-27	
Vibration resistance		50m/s <sup>2</sup> (10 to 500Hz) IEC 60068-2-6		
Tongued key operating speed		0.01m/s to 0.5m/s		
Mechanical operating frequency		10 operations/min.		
Life	Mechanical life	1million operations or more		
	Electrical life	1million operations or more		
Environmental conditions	Operating temperature range	-25 to +40°C (No freezing allowed.)		
	Operating humidity range	85%RH or less		
Recommended tightening torque	Body	5 to 6N-m (M5 hexagon socket head cap bolt)		
	Cover	1.5 to 3.0N-m (M5 round head screw), 1.5N-m (M4 round head screw)		
	Terminal	0.8N-m (M3 binding machine screw)		

• Installation Instructions No.: CP-UM-5213E

Note. Category used AC-15: Solenoid load  
DC-13: Solenoid load

Ue: Operating rated voltage

Ie: Operating rated current

## CONTACT OPERATION

Catalog listing	LJS-E5312, LJS-E5512	LJS-E7312, LJS-E7512
<p>  : Contact close   : Contact open   : Transient state                 </p>	<p>Tongued key insertion (NORMAL) state</p>	<p>Tongued key insertion (NORMAL) state</p>
Circuit diagram		

## OPERATING CHARACTERISTICS AND EXTERNAL DIMENSIONS

### • Body

(unit: mm)

Tongued key removal strength (when locked)	2,000N
Forced opening force (Min.)	20N

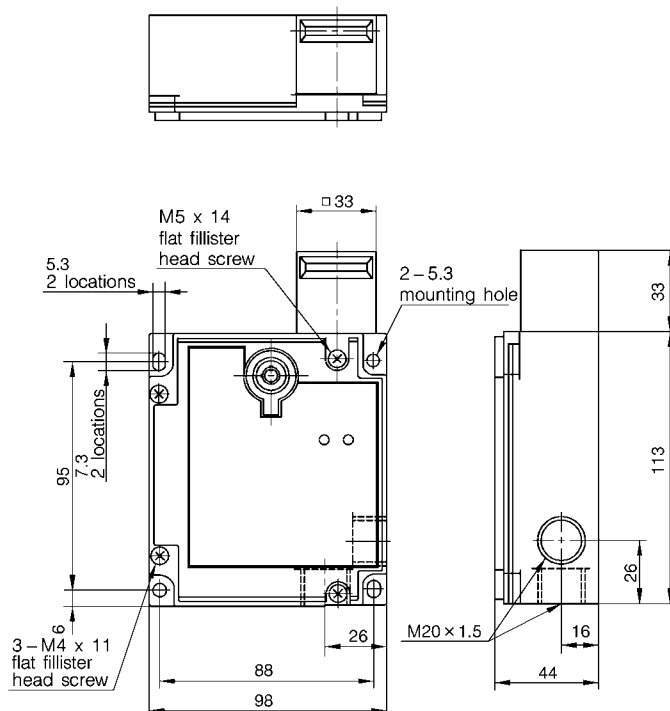

● Tongued key

**LJS-Z01**

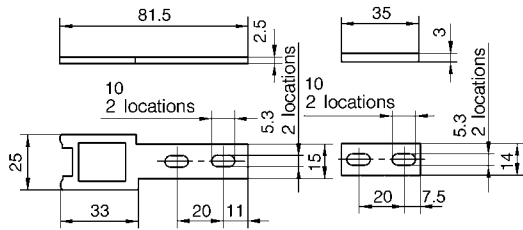

**LJS-Z02**

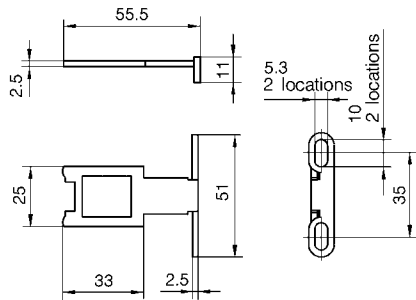

**LJS-Z03**

(unit: mm)

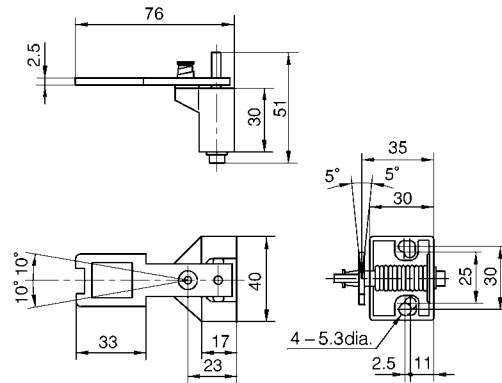

**CIRCUIT EXAMPLES**

● Example of circuit in category 1 of EN 954-1

Example of circuit, in which a protective fuse is used to prevent the N.C. contact from being closed due to damaged cable or intentional change.

N.C. + N.O. + N.O. (**LJS-E5312**)

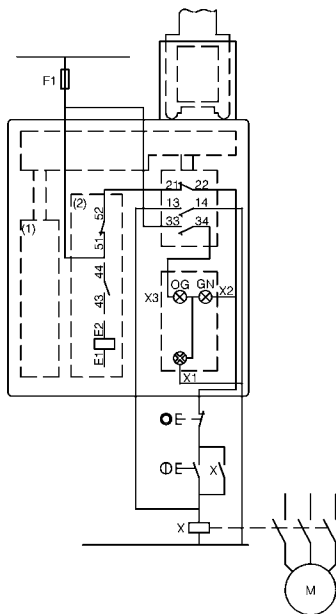

- (1) Solenoid
- (2) Auxiliary contact
- E1-E2: Solenoid power supply (Non-polarity)
- 43-44: Contact for solenoid signal
- 13-14: Contact used as redundancy
- 33-X1: LED (Orange)  
Energized when the tongued key is removed.
- 51-X1: LED (Green)  
Energized when the tongued key is inserted and locked.
- 21-52: Wiring necessary for safety

● Example of circuit in category 3 of EN 954-1

Example of circuit, in which the switch contact has redundancy without monitor.

N.C. + N.C. + N.O. (**LJS-E7312**)

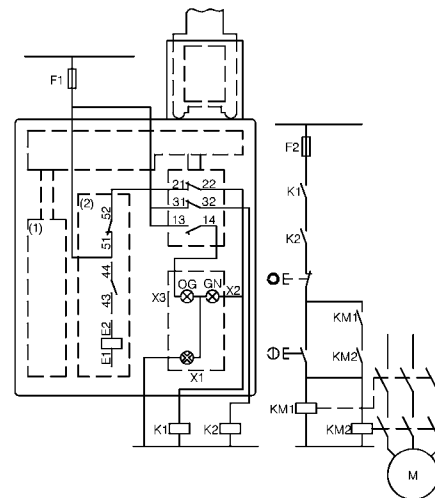

- (1) Solenoid
- (2) Auxiliary contact
- E1-E2: Solenoid power supply (Non-polarity)
- 43-44: Contact for solenoid signal
- 31-32: Contact used as redundancy
- 13-X1: LED (Orange)  
Energized when the tongued key is removed.
- 51-X1: LED (Green)  
Energized when the tongued key is inserted and locked.
- 21-52: Wiring necessary for safety

● Diagram of tongued key position

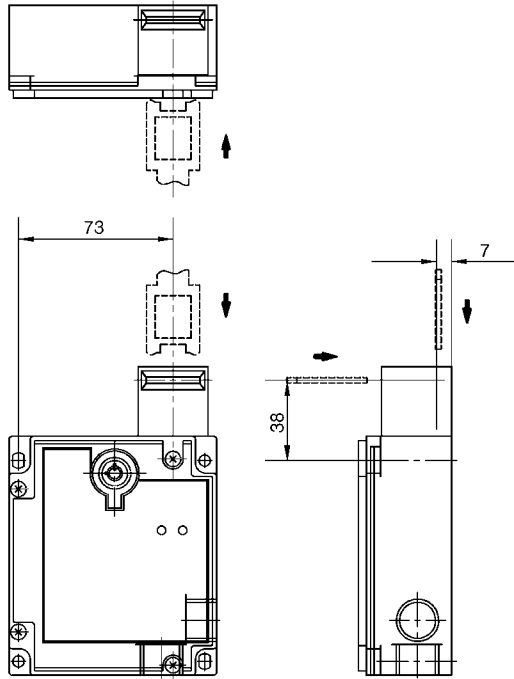

● Diagram of tongued key insertion position

(unit: mm)

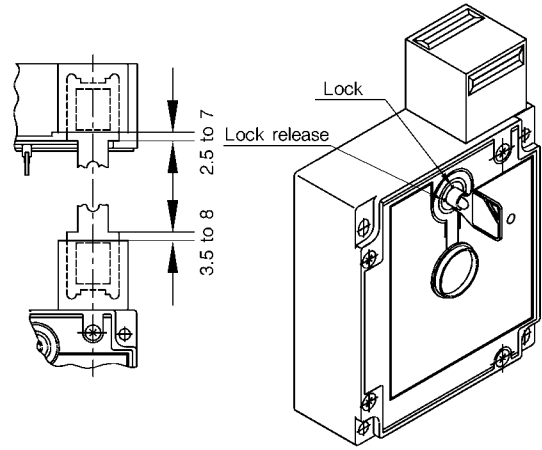

● Actuation radius of tongued key  
LJS-Z01/Z02

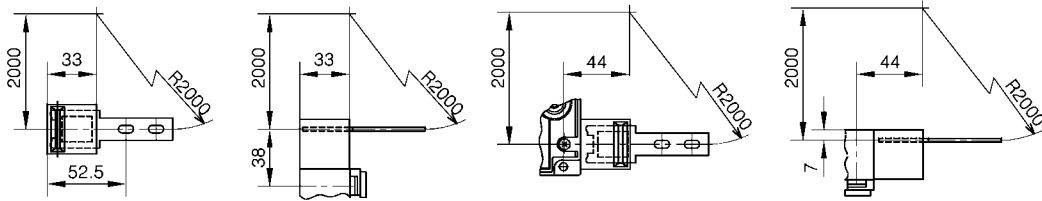

LJS-Z03

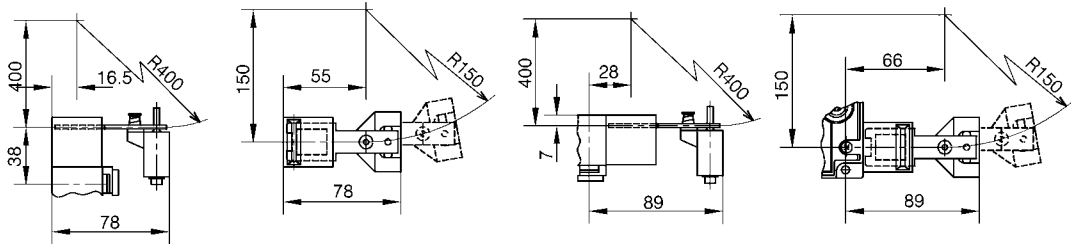

## STRUCTURAL DIAGRAM

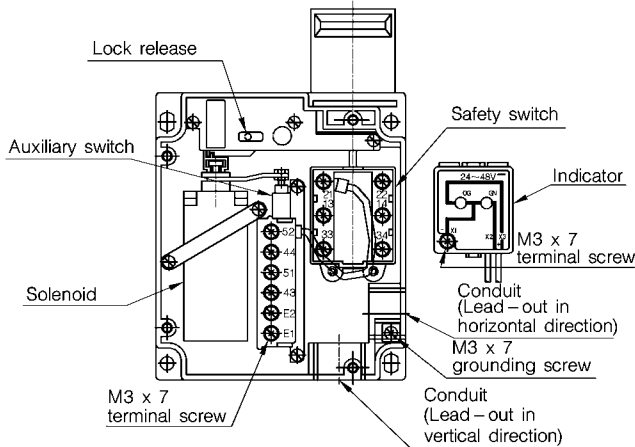

## GENERAL CIRCUIT DIAGRAMS

LJS-E5312

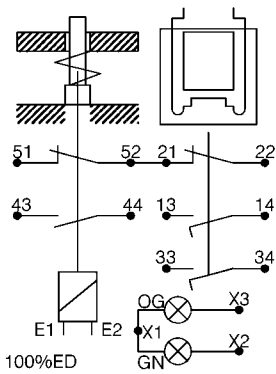

LJS-E7312

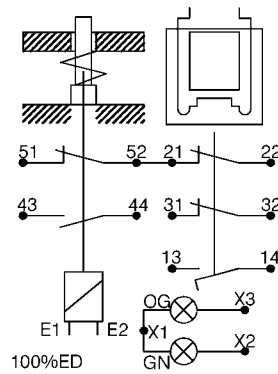

LJS-E5512

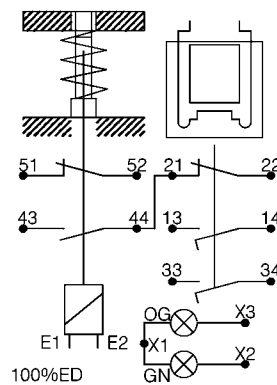

LJS-E7512

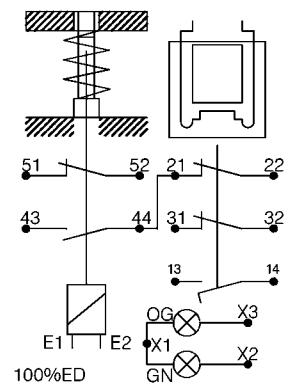

## HANDLING PRECAUTIONS

### ● Mounting the switch

- Always tighten each part of the safety switch with the recommended tightening torque stated in the product specification. If any part is tightened excessively, this might cause damage to the screw and/or other parts. Additionally, insufficient tightening may lead to lowering of various characteristics, such as switch sealing ability.
- Regardless of the door type, do not use the safety switch for the door stopper.  
A mechanical door stopper is installed at the end of the door so that any excessive force is not applied to the safety switch.
- Do not apply any excessive impact to the safety switch by opening or closing the door carelessly. If any excessive impact is applied to the switch, this might cause the switch to malfunction.
- When the safety switch is operated in a place where a large amount of foreign matter or dust exists, appropriate measures, such as protective cover are taken to prevent foreign matter or dust from entering the safety switch through the tongued key insertion port. If a large amount of foreign matter or dust enters the safety switch, this may affect the mechanical part, resulting in malfunction.

### ● Tongued key

- Do not use any tongued key other than that specified. Operation with a tongued key other than that specified might cause the switch to break.
- Mount the tongued key in a place where it is not in contact with the operator's body when opening or closing the door. Failure to do so might cause personal injury.  
To properly and safely operate the switch, see also the separate Installation Instructions, "Safety Interlock Switch **LJS-E Series**", (Installation Instructions No.: **CP-UM-5213E**).

# LJS-TE Series

## Plastic Safety Interlock Switches with Solenoid Lock

### FEATURES

Safety Interlock Switches with Solenoid Lock Made of Plastic.

- UL/CSA/CE markings provided.
- $\text{\textcircled{C}}$ contact forced open mechanism provided. (N.C. contact only)
- High sealing ability. (IP67)
- Double-insulation structure with plastic housing.  
(No grounding line connection required.)

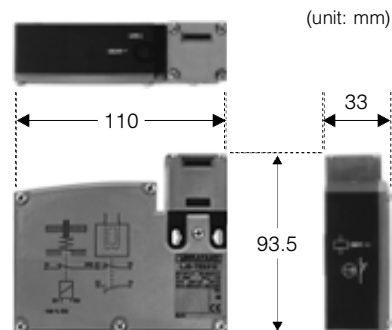



For details about dimensions, see relevant drawings.

### ORDER GUIDE

#### ● Body

Contact type	Lock method	Catalog listing
N.C. × 2	Locked when solenoid is not energized.	<b>LJS-TE7312</b>
N.C. × 1 + N.O. × 1		<b>LJS-TE5312</b>
N.C. × 2	Locked when solenoid is energized.	<b>LJS-TE7512</b>
N.C. × 1 + N.O. × 1		<b>LJS-TE5512</b>

#### ● Tongued key

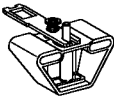
Shape	Catalog listing
Straight type 	<b>LJS-Z11</b>
Right angle type 	<b>LJS-Z12</b>
Adjustable type 	<b>LJS-Z13</b>

### INTERNAL SWITCH

The internal switch of the **LJS-TE** Series has the N.C./N.O. electrically independent contact (Zb) structure.

Additionally, the contact forced open structure is used to forcibly open the contact (N.C. contact only) even if the contact is fused accidentally.

As the switch is pushed in, the contact is opened forcibly.

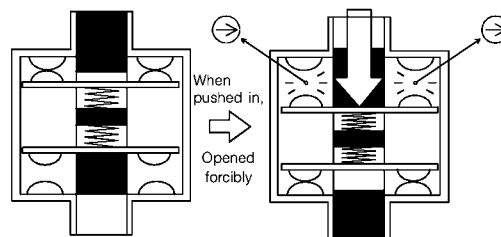

## PERFORMANCE

Catalog listing		LJS-TE□312	LJS-TE□512	
Standards	Conformed standards	Product related: IEC 60947-5-1, EN 60947-5-1 ⊕ Machine related: IEC 60204-1, EN 60204-1, EN 1088		
	Approved standards	UL/CSA		
Structure	Protective structure	IP67 (JIS C 0920), (IEC 60529)		
	Electrical shock protection	class II (IEC 60536)		
	Internal switch	Slow action		
	Lock method	Locked when solenoid is not energized.	Locked when solenoid is energized.	
Electrical performance	Body	Electrical rating (Note)	AC-15: B300 (U <sub>e</sub> =240V, I <sub>e</sub> =1.5A or U <sub>e</sub> =120V, e=3A) DC-13: Q300 (U <sub>e</sub> =250V, I <sub>e</sub> =0.27A or U <sub>e</sub> =125V, I <sub>e</sub> =0.55A)	
		Rated energizing current (I <sub>th</sub> )	6A	
		Short-circuit protective device	Breaking fuse 10A type gG (gl)	
		Rated insulation voltage (U <sub>i</sub> )	500V IEC 60947-1, 300V UL 508/CSA	
		Conditional rated short-circuit current	1,000A	
		Rated impulse withstanding voltage (U <sub>imp</sub> )	4,000V	
	Solenoid coil	Load factor	100%	
		Rated energizing current	AC/DC 24V	
		Allowable voltage variation range	-20%, +10%	
		Electrical life	Average life: 20,000hrs.	
		Power consumption	Rush: 10VA, Retention: 10VA	
Mechanical performance	Impact resistance	100m/s <sup>2</sup> (11ms) IEC 60068-2-27		
	Vibration resistance	50m/s <sup>2</sup> (10 to 500Hz) IEC 60068-2-6		
	Tongued key operating speed	0.01m/s to 0.5m/s		
	Mechanical operation frequency	10 operations/min.		
Life	Mechanical life	1million operations or more		
	Electrical life	1million operations or more		
Environmental conditions	Operating temperature range	-25 to +60°C (No freezing allowed.)		
	Operating humidity range	85%RH or less		
Recommended tightening torque	Body	0.49 to 0.69N-m (M4 screw)		
	Cover	0.5N-m (M3 round head screw)		
	Head	0.5N-m (M3 round head screw)		
	Terminal: Body	0.8N-m (M3.5 binding machine screw)		
	Terminal: Solenoid and auxiliary switch	0.5N-m (M3 binding machine screw)		



- Installation Instructions No.: CP-SP-5214E

Note. Category used AC-15: Solenoid load  
DC-13: Solenoid load

U<sub>e</sub>: Rated operating voltage

I<sub>e</sub>: Rated operating current

## CONTACT OPERATION

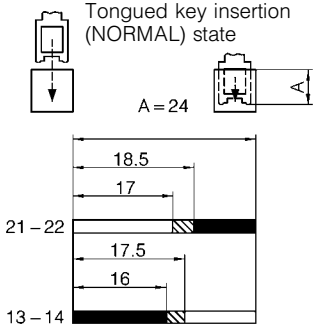
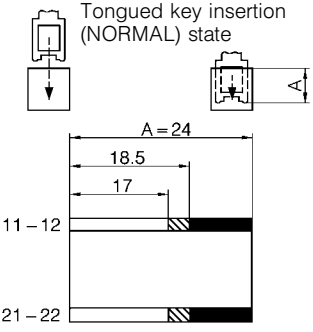
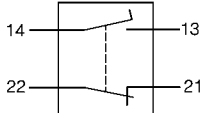
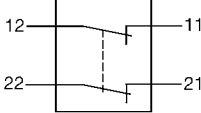
Catalog listing	LJS-TE5312, LJS-TE5512	LJS-TE7312, LJS-TE7512
<p>  : Contact close   : Contact open   : Transient state                 </p>	<p>Tongued key insertion (NORMAL) state</p> 	<p>Tongued key insertion (NORMAL) state</p> 
Circuit diagram		

## OPERATING CHARACTERISTICS AND EXTERNAL DIMENSIONS

### ● Body

Tongued key removal strength (when locked)	500N
Forced opening force (Min.)	15N

(unit: mm)

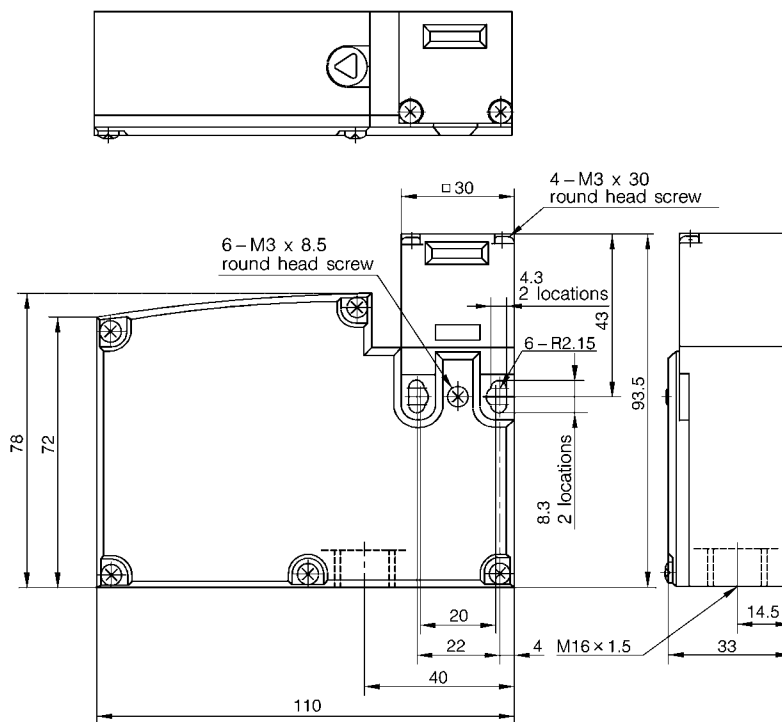

● Tongued key

LJS-Z11

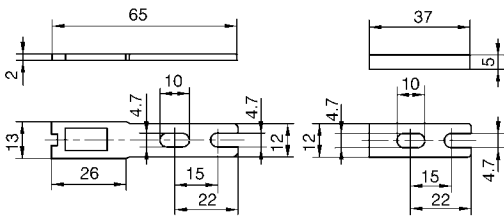

LJS-Z12

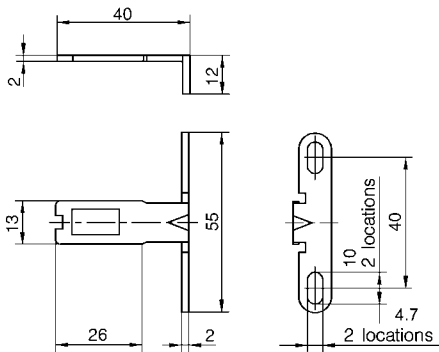

LJS-Z13

(unit: mm)

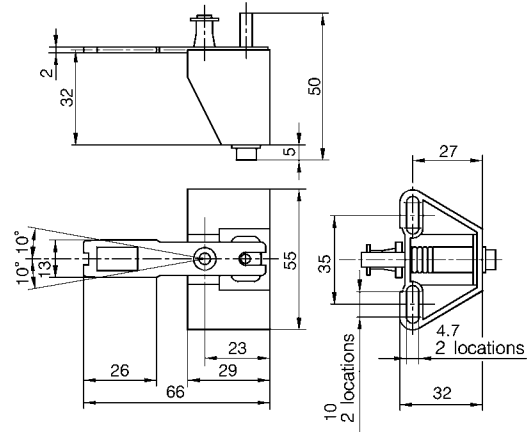

**CIRCUIT EXAMPLES**

• Example of circuit in category 1 of EN 954-1

Example of circuit, in which a protective fuse is used to prevent the N.C. contact from being closed due to damaged cable or intentional change.

N.C. + N.O. (LJS-TE5312)

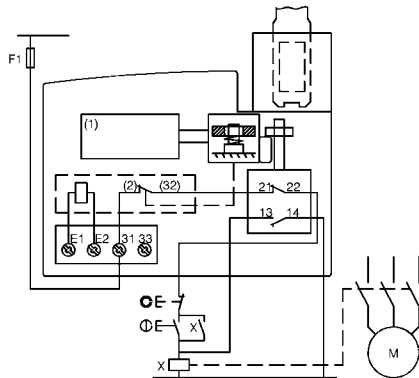

- (1) Solenoid
- (2) Auxiliary contact
- E1-E2: Solenoid power supply (Non-polarity)
- 13-44: Contact used for redundancy and signal

• Example of circuit in category 3 of EN 954-1

Example of circuit, in which the switch contact has redundancy without monitor.

N.C. + N.C. (LJS-TE7312)

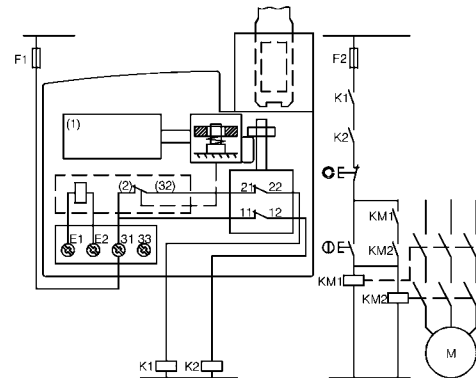

- (1) Solenoid
- (2) Auxiliary contact
- E1-E2: Solenoid power supply (Non-polarity)
- 11-12: Contact used as redundancy

● Diagram of tongued key position

● Diagram of tongued key insertion position

(unit: mm)

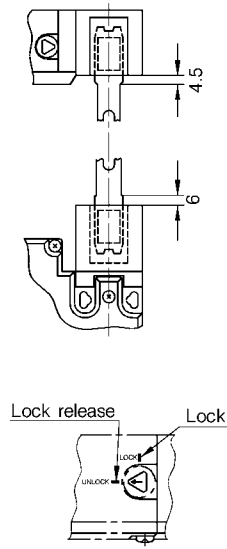
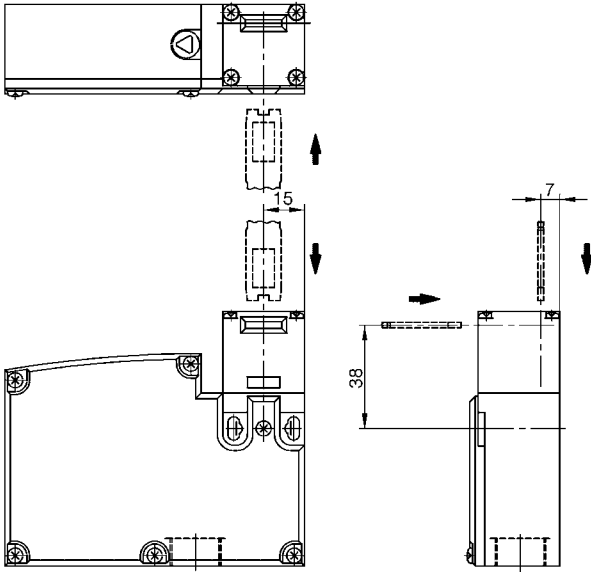

● Actuation radius of tongued key  
LJS-Z11/Z12

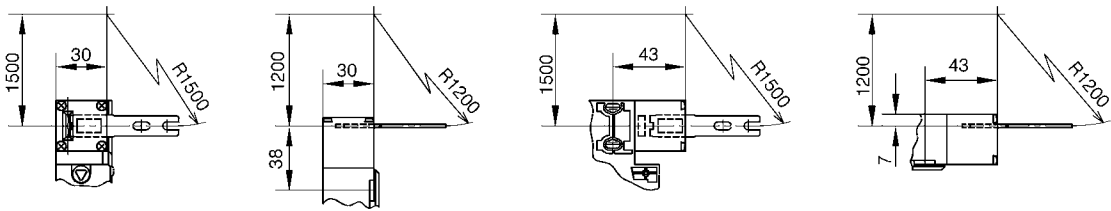

LJS-Z13

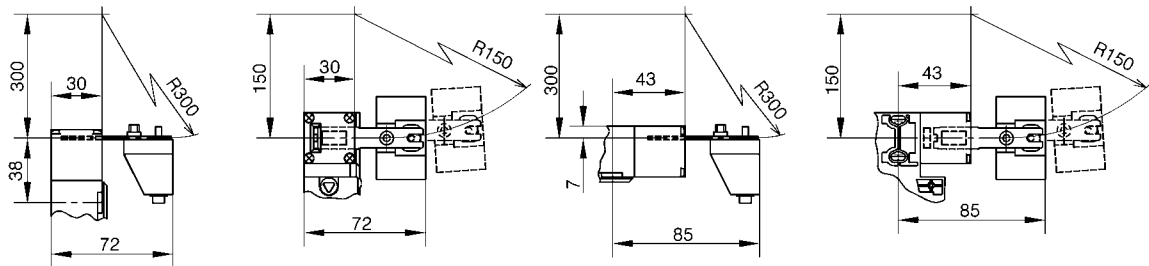

## STRUCTURAL DIAGRAM

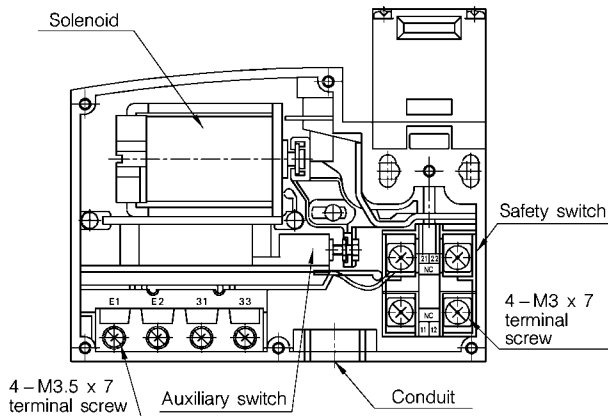

## GENERAL CIRCUIT DIAGRAMS

LJS-TE5312

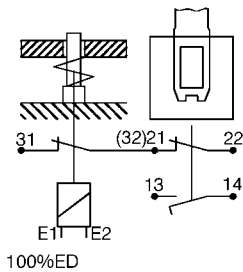

LJS-TE7312

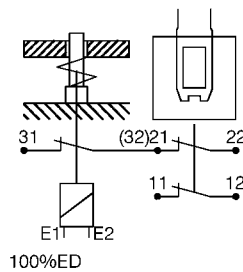

LJS-TE5512

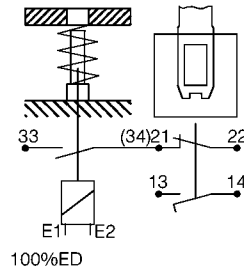

LJS-TE7512

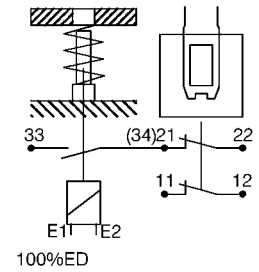

## HANDLING PRECAUTIONS

### ● Mounting the switch

- Always tighten each part of the safety switch with the recommended tightening torque stated in the product specification. If any part is tightened excessively, this might cause damage to the screw and/or other parts. Additionally, insufficient tightening may lead to lowering of various characteristics, such as switch sealing ability.
- Regardless of the door type, do not use the safety switch for the door stopper.  
A mechanical door stopper is installed at the end of the door so that any excessive force is not applied to the safety switch.
- Do not apply any excessive impact to the safety switch by opening or closing the door carelessly. If any excessive impact is applied to the switch, this might cause the switch to malfunction.
- When the safety switch is operated in a place where a large amount of foreign matter or dust exists, appropriate measures, such as protective cover are taken to prevent foreign matter or dust from entering the safety switch through the tongued key insertion port. If a large amount of foreign matter or dust enters the safety switch, this may affect the mechanical part, resulting in malfunction.

### ● Tongued key

- Do not use any tongued key other than that specified.  
Operation with a tongued key other than that specified might cause the switch to break.
- Mount the tongued key in a place where it is not in contact with the operator's body when opening or closing the door. Failure to do so might cause personal injury.

To properly and safely operate the switch, see also the separate Installation Instructions, "Safety Interlock Switch **LJS-TE** Series", (Installation Instructions No.: **CP-UM-5214E**).

## Special seal connector for safety switch

### Seal connector PA1 Series for metric screw

#### FEATURES

Seal Connector for Cable to be Connected to Safety Switch.

#### CATALOG LISTINGS

Catalog listing	Outside diameter of applicable cable	Nominal size of screw
<b>PA1-A1M1</b>	4 to 8mm	M20 × 1.5
<b>PA1-A2M1</b>	8 to 12mm	
<b>PA1-A10M1</b>	6 to 10mm	

#### STRUCTURE OF PARTS

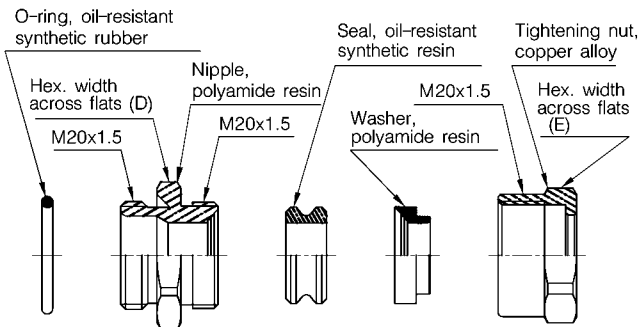

#### EXTERNAL DIMENSIONS

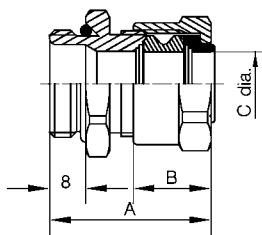

(unit: mm)

Catalog listing	(A)	B	C	Hex. width across flats of nipple (D)	Hex. width across flats of tightening nut (E)
<b>PA1-A1M1</b>	(30 to 35)	17.0	8.3	26.4	22.0
<b>PA1-A2M1</b>	(30 to 35)	17.0	12.3	26.4	26.4
<b>PA1-A10M1</b>	(30 to 35)	17.0	10.3	26.4	26.4

**Note 1.** Secure the nut to the body with a tightening torque of 8 to 12N-m.

**Note 2.** For tightening torque of the tightening nut, tighten the nut further 1.5 to 2 rotations after the cable is no longer moved so that the nut is closely in contact with the nipple.

# Seal connector PA4-M Series for metric screw

## FEATURES

Resin Seal Connector for Cable to be Connected to Safety Switch.

## CATALOG LISTING

Catalog listing	Outside diameter of applicable cable	Paint color
<b>PA4-M2B</b>	4 to 8mm	Black
<b>PA4-M4B</b>	8 to 11mm	Black

## STRUCTURE OF PARTS

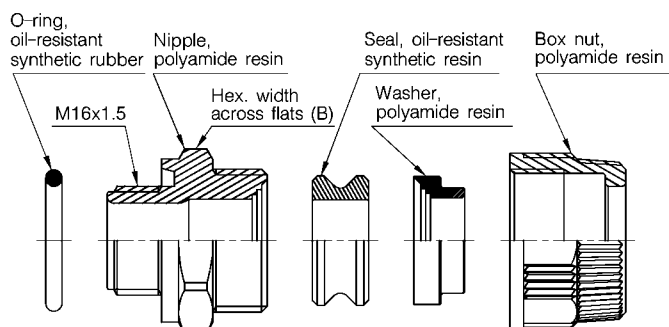

## EXTERNAL DIMENSIONS

(unit: mm)

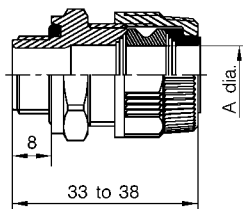

Catalog listing	A	Hex. width across flats of nipple (B)
<b>PA4-M2B</b>	8.2	22.5
<b>PA4-M4B</b>	12.2	27.0

**Note 1.** Secure the nut to the body with a tightening torque of 2.5 to 3.5N-m.

**Note 2.** For tightening torque of the tightening nut, tighten the nut further 1.5 to 2 rotations after the cable is no longer moved so that the nut is closely in contact with the nipple.

MEMO



## RESTRICTIONS ON USE

This product has been developed, designed and manufactured for safety-purpose application in accordance with “Guidelines for Comprehensive Safety Standards of Machinery -Ministry of Health, Labour and Welfare-”.

Accordingly, when used in applications outlined below, special care should be taken to implement a fail-safe and/or redundant design concept as well as a periodic maintenance program.

- Start/stop control devices for transportation and material handling machines
- Aeronautical/aerospace machines
- Control devices for nuclear reactors

Never use this product in applications where human safety may be put at risk.

**YAMATAKE**

*Specifications are subject to change without notice.*

**Yamatake Corporation**  
**Advanced Automation Company**

**International Business Headquarters**

Totate International Building

2-12-19 Shibuya Shibuya-ku

Tokyo 150-8316 Japan

URL:<http://www.yamatake.com>

This has been printed on 100% recycled paper.

(01)

Printed in Japan (SP)

1st Edition: Issued in Apr., 2003

2nd Edition: Issued in Oct., 2003